

Test Note : Example SIP Configurations for use with AVAYA IP Office Release 4.0

Example SIP Configurations for use with AVAYA IP Office Release 4.0

During the 4.0 field trials in Late 2006 we conducted some testing with an IP 500 base unit with a VCM 32 Card, SIP Licences configured to use four SIP carriers based in Australia.

The carriers we conducted testing with were



MyTel

<http://www.mytel.net.au>



Soul Australia

<http://www.soul.com.au>



ISPhone

<http://www.isphone.com.au>



Engin

<http://www.engin.com.au>

We simply provide this document to help with the configuration to the carriers above. However the documented settings will help you in configuring to any SIP carrier regardless if they require authentication or not, the IP Office 4.0 supports both.

In all the configs we used ARS (Alternate Route Selection), You are able to configure many concurrent carriers with unique Line Group ID,s using different ARS Short codes to route the calls based on cost of call. The tests and procedures were conducted on an IP Office 500 Firmware 4.0(38) connected directly to the public Internet via WAN port with IP Address of 211.27.21.53/29. LAN1 was connected to the 200.0.0/24 network for management purposes. No NAT or Firewalls were present on the external WAN interface, these tests were simply to confirm connectivity and feature set.

The setting and test results were correct at time of writing this document, we will not be held responsible if these settings are no longer correct, or you are unable to connect to the carrier outlined in this document.

The following test scenarios were conducted with all four carriers.

	Mytel	Engin	ISPhone	Soul
IPO Outbound PSTN				
Call ringback:	X	X	X	X
Voice cut through on connect G.729a	X	X	X	X
Ringback terminated on caller disconnect	X	X	X	X
long duration call: 1 hour			X	X
DTMF relay	X	X	X	X
Called party disconnect; calling party automatically disconnected	X	X	X	X
Calling party disconnect; called party automatically disconnected	X	X	X	X
PSTN inbound to IPO				
Call ringback:	X		X	X
Voice cut through on connect	X		X	X
Ringback terminated on caller disconnect	X		X	X
long duration call: 1 hour	X		X	X
DTMF relay	X		X	X
Called party disconnect; calling party automatically disconnected	X		X	X
Calling party disconnect; called party automatically disconnected	X		X	X
IPO Conference Call				
Digital IPO Phone to PSTN Hold Phone2 Hold PSTN Phone all Conference	X	X	X	X
Digital IPO Phone to Digital IPO Phone Internally conference in PSTN User	X	X	X	X
PSTN to Phone1 Hold Call IPO Digital Phone2 Conference		X	X	X
PSTN to Voicemail				
PSTN to IPO: retrieve voice mail	X		X	X
PSTN to IP IPO: leave voice mail	X		X	X
Call Hold and Resume				
IPO to PSTN	X	X	X	X
PSTN to IPO	X		X	X
IPO to Dell Support 1800816818 - 1-2-1-2-7				
Call ringback:	X	X	X	X
Voice cut through on connect to initial voice prompt	X	X	X	X
Interact with voice prompt using DTMF for as long as possible (more than 30 seconds)	X	X	X	X
Calling party disconnect; called party automatically disconnected (verify with ethereal trace)	X	X	X	X
Voice Quality				
IPO to PSTN	X	X	X	X
Inbound to IPO	X		x	x
Simultaneous Calls (Minimum 2)				
IPO to PSTN	2	2	2	2
Inbound to IPO	2		2	2
PSTN to IPO (CLI Presented)	X		X	X*

* Can be enabled on a different service that Soul Offer

See below detailed information regarding the IP 500 Configuration

Basic Network Diagram

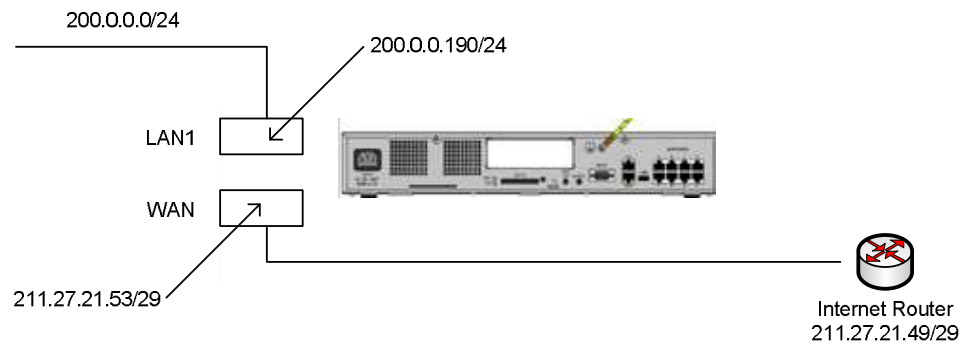

LAN1 Settings

System	LAN1	LAN2	DNS	Voicemail	Telephony	LDAP	System Alarms	Twinning	CDR		
LAN Settings		Gatekeeper	Network Topology								
IP Address	200 . 0 . 0 . 190										
IP Mask	255 . 255 . 255 . 0										
Primary Trans. IP Address	0 . 0 . 0 . 0										
RIP Mode	None										
	<input type="checkbox"/> Enable NAT										
Number Of DHCP IP Addresses	1										
DHCP Mode											
<input type="radio"/> Server				<input type="radio"/> Client		<input type="radio"/> Dialin		<input checked="" type="radio"/> Disabled			

LAN2 (WAN Port) Settings

System	LAN1	LAN2	DNS	Voicemail	Telephony	LDAP	System Alarms	Twinning	CDR		
LAN Settings		Gatekeeper	Network Topology								
IP Address	211 . 27 . 21 . 53										
IP Mask	255 . 255 . 255 . 248										
Primary Trans. IP Address	0 . 0 . 0 . 0										
Firewall Profile	<None>										
RIP Mode	None										
	<input type="checkbox"/> Enable NAT										
Number Of DHCP IP Addresses	200										
DHCP Mode											
<input type="radio"/> Server				<input type="radio"/> Client		<input type="radio"/> Dialin		<input checked="" type="radio"/> Disabled			

LAN2 Gatekeeper Settings

System | LAN1 | LAN2 | DNS | Voicemail | Telephony | LDAP | System Alarms | Twinning | CDR

LAN Settings | Gatekeeper | Network Topology

H323 Gatekeeper Enable SIP Proxy Enable

H323 Auto-create Extn

H323 Auto-create User

RTP Port Number Range

Port Range (Minimum) 49152

Port Range (Maximum) 53246

DiffServ Settings

88 DSCP(Hex) FC DSCP Mask (Hex) 88 SIG DSCP (Hex)

46 DSCP 63 DSCP Mask 34 SIG DSCP

176 Site Specific Option Number (SSON)

LAN2 STUN Settings

System | LAN1 | LAN2 | DNS | Voicemail | Telephony | LDAP | System Alarms | Twinning | CDR

LAN Settings | Gatekeeper | Network Topology

Network Topology Discovery

STUN Server IP Address 69 . 90 . 168 . 13

Firewall/NAT Type Open Internet

Binding Refresh Time (seconds) 20

Public IP Address 211 . 27 . 21 . 53

Public Port 5060

Run STUN Cancel

Rerun STUN on failure

See below License Valid and Control Unit Used

 SIP Trunk Channels

Valid

Control Unit

Dev No.	Dev Type	Version
1	IP 500	4.0 (11038)
2	PHONE8/ATM4	4.0 (11038)
3	DIGSTA8/BRI8	4.0 (11038)
5	VCM32	4.0 (11038)



MyTel Configuration

The testing was conducted on 4.0 Pre Release

Notes:

MyTel do not require the number to be presented to them in International format
MyTel SIP account can be accessed from any public accessible device

Details we were given from the carrier

"SIP Server" to gw02.mytel.net.au

"Registration Server" set this to gw02.mytel.net.au

"SIP User ID" (and "Authenticate ID" too, if it's there) to 357108

"Display Name" to Test user

"Password" to XXXX (Hidden for Security Reasons)

Set the preferred codec to GSM **or** G729a

In-dial Number on Service 02 90372208

These relate to the following fields in the IP Office 4.0 Config

"SIP Server" to gw02.mytel.net.au and "Registration Server" set this to gw02.mytel.net.au

IPO FIELD = ITSP IP Address - 203.166.130.242

The IP Office does not have the ability to resolve DNS addresses so you have to enter the IP Address, Note however if the carrier updates the SIP Server in DNS to reflect a different IP Address your calls will fail and the ITSP field will need to be reconfigured to reflect the new Server IP Address. You can obtain the IP address of the DNS entry by using NSLOOKUP in Windows command prompt.

Set "SIP User ID" (and "Authenticate ID" too, if it's there) to 357108

IPO FIELD = Primary Authentication Name: - 357108

Set "Password" to XXXX (Hidden for Security Reasons)

Primary Authentication Password: XXXXXX (Hidden for Security Reasons)

If possible, set the preferred codec to GSM or G729a

IPO FIELD - Compression Mode: G.729(a) CS-ACLEP

Set this field to G.729(a) CS-ACLEP

The IP Office does not support GSM Codecs

IPO FIELD - Registration Required: Ticked

IPO FIELD - In Service: Ticked

IPO FIELD - Primary Registration Expiry: 60 but could be 3600 depending on how often you wish to refresh your registration.

See below Screen Shot of the SIP Line 10

SIP Line - Line 10*

SIP Line SIP URI

Line Number: 10

ITSP Domain Name: mytel.net.au

ITSP IP Address: 203 . 166 . 103 . 242

Primary Authentication Name: 357108

Primary Authentication Password: XXXXXX

Primary Registration Expiry: 60

Secondary Authentication Name:

Secondary Authentication Password:

Secondary Registration Expiry: 900

Registration Required:

In Service:

Use Tel URI:

VoIP Silence Suppression:

Out Of Band DTMF:

Local Tones:

Fax T38:

RE-INWITE Supported:

Voice Packet Size: 20

Compression Mode: G.729(a) 8K CS-ACE

Network Configuration

Layer 4 Protocol: UDP

Use Network Topology Info: LAN 2

Send Port: 5060

Listen Port: 5060

SIP Line - Line 10

SIP Line SIP URI

Channel	Groups	Via	Local URI	Contact
1	249 249	211.27.21.53	357108	357108

Edit Channel

Via: 211.27.21.53

Local URI: Use Authentication Name

Contact: Use Authentication Name

Display Name: Use Authentication Name

Registration: Primary

Incoming Group: 249

Outgoing Group: 249

Max Calls per Channel: 10

We gave the Line Incoming and Outgoing Group 249
All Local URI, Contact and Display names were set to "Use Authentication Name"

See below ARS configuration including SIP Short code for 9 numbers

The screenshot shows the 'ARS' configuration window. The title bar is 'Main*'. The window contains the following fields and controls:

- ARS Route Id: 50
- Route Name: Main
- Dial Delay Time: System
- Secondary Dial tone: SystemTone
- Check User Call Barring:
- In Service: (connected to Out of Service Route: <None>)
- Time Profile: <None> (connected to Out of Hours Route: <None>)
- Code: 9XXXXXXX
- Telephone Number: 9N@203.166.130.242
- Feature: Dial
- Line Group Id: 249
- Buttons: Add..., Remove, Edit...
- Alternate Route Priority Level: 3
- Alternate Route Wait Time: 30
- Additional Route: <None>
- Buttons: OK, Cancel, Help

INCOMING CONFIGURATION

See below Incoming call route directed to Extension 210 for Incoming Line Group 249

The screenshot shows the 'Incoming call route' configuration window for Line Group Id 249. The title bar is '249'. The window contains the following fields and controls:

- Standard | Voice Recording
- Bearer Capability: Any Voice
- Line Group Id: 249
- Incoming Number:
- Incoming Sub Address:
- Incoming CLI:
- Destination: 210 Extn210
- Locale:
- Priority: 1
- Fallback Extension:
- Night Service Profile: <None>
- Night Service Destination:

See below Sys-Monitor trace of Extension 210 to 96677152 via SIP Line 249 as per ARS settings.

```
2050891mS PRN: Monitor Status IP 500 4.0(11037)
2050891mS PRN: LAW=A PRI=0, BRI=4, ALOG=4, ADSL=0 VCOMP=32, MDM=0, WAN=0, MODU=0 LANM=0
CkSRC=0 VMAIL=0(VER=0 TYP=1) CALLS=0(TOT=1)
2129314mS PRN: Loading holdmusic.wav from ipad=255.255.255.255
2174319mS PRN: WAV Hold Music Load Failed
2457742mS SipDebugInfo: SIPTrunks: Make Target voip, line group id is 249 and ip of cba667f2
2457742mS SipDebugInfo: SIPTrunks: active channels 0 overall number 10
2457742mS SipDebugInfo: License, Valid 1, Available 255, Consumed 0
2457745mS SipDebugInfo: MZ extension is dialing 96677152@203.166.130.242

2457745mS SipDebugInfo: MZ extension is dialing 96677152@203.166.130.242
2457745mS SipDebugInfo: *****
2457745mS SipDebugInfo: MZ: INVITE (method) SENT TO 203.166.103.242 5060
2457745mS SipDebugInfo: *****
2457747mS SipDebugInfo: *****
2457747mS SipDebugInfo: MZ: INVITE SENT TO 203.166.103.242 5060
2457747mS SipDebugInfo: *****
2457747mS SipDebugInfo: MZ: Entered Sip_sendToNetwork packet destination is 203.166.103.242

2457748mS SipDebugInfo: MZ SIPTrunk SendToTarget cba667f2, 5060
2457748mS SIP Trunk: 10:Tx
  INVITE sip:96677152@203.166.130.242 SIP/2.0
  Via: SIP/2.0/UDP 211.27.21.53:5060;rport;branch=z9hG4bKc95a5f97a7d206629607ef8c25a77fc1
  From: 357108 <sip:357108@mytel.net.au>;tag=4f9d0b6d969ac7b7
  To: <sip:96677152@203.166.130.242>
  Call-ID: 7a85a3772f4969ae81c7c4579d12eb55@211.27.21.53
  CSeq: 1755202939 INVITE
  Contact: 357108 <sip:357108@211.27.21.53:5060;transport=udp>
  Max-Forwards: 70
  Allow: INVITE, ACK, CANCEL, OPTIONS, BYE
  Content-Type: application/sdp
  Content-Length: 300

  v=0
  o=UserA 2191955339 564929546 IN IP4 211.27.21.53
  s=Session SDP
  c=IN IP4 211.27.21.53
  t=0 0
  m=audio 49152 RTP/AVP 18 4 8 0 101
  a=rtpmap:18 G729/8000
  a=rtpmap:4 G723/8000
  a=rtpmap:8 PCMA/8000
  a=rtpmap:0 PCMU/8000
  a=fmtp:18 annexb = no
  a=rtpmap:101 telephone-event/8000
  a=fmtp:101 0-15
2457748mS SIP Tx: UDP 211.27.21.53:5060 -> 203.166.103.242:5060

  INVITE sip:96677152@203.166.130.242 SIP/2.0
  Via: SIP/2.0/UDP 211.27.21.53:5060;rport;branch=z9hG4bKc95a5f97a7d206629607ef8c25a77fc1
  From: 357108 <sip:357108@mytel.net.au>;tag=4f9d0b6d969ac7b7
  To: <sip:96677152@203.166.130.242>
  Call-ID: 7a85a3772f4969ae81c7c4579d12eb55@211.27.21.53
  CSeq: 1755202939 INVITE
  Contact: 357108 <sip:357108@211.27.21.53:5060;transport=udp>
  Max-Forwards: 70
  Allow: INVITE, ACK, CANCEL, OPTIONS, BYE
  Content-Type: application/sdp
  Content-Length: 300

  v=0
  o=UserA 2191955339 564929546 IN IP4 211.27.21.53
  s=Session SDP
  c=IN IP4 211.27.21.53
  t=0 0
  m=audio 49152 RTP/AVP 18 4 8 0 101
  a=rtpmap:18 G729/8000
```

```

a=rtpmap:4 G723/8000
a=rtpmap:8 PCMA/8000
a=rtpmap:0 PCMU/8000
a=fmtp:18 annexb = no
a=rtpmap:101 telephone-event/8000
a=fmtp:101 0-15
2457748mS SipDebugInfo: initialising mTxnContext
2457749mS SipDebugInfo: *****
2457749mS SipDebugInfo: State Transition form Old State 0 to New state 1
2457749mS SipDebugInfo: *****
2457749mS SipDebugInfo: SIPDialog::UpdateSDPState has just transitioned to state 1
2457870mS SIP Rx: UDP 203.166.103.242:5060 -> 211.27.21.53:5060

SIP/2.0 407 Proxy Authentication Required
Via: SIP/2.0/UDP
211.27.21.53:5060;branch=z9hG4bKc95a5f97a7d206629607ef8c25a77fc1;received=211.27.21.53;rport=5060
From: 357108 <sip:357108@mytel.net.au>;tag=4f9d0b6d969ac7b7
To: <sip:96677152@203.166.130.242>;tag=as457ad6f5
Call-ID: 7a85a3772f4969ae81c7c4579d12eb55@211.27.21.53
CSeq: 1755202939 INVITE
User-Agent: Asterisk PBX
Allow: INVITE, ACK, CANCEL, OPTIONS, BYE, REFER, SUBSCRIBE, NOTIFY
Proxy-Authenticate: Digest algorithm=MD5, realm="asterisk", nonce="31e9766d"
Content-Length: 0

2457870mS SIP Trunk: 10:Rx
SIP/2.0 407 Proxy Authentication Required
Via: SIP/2.0/UDP
211.27.21.53:5060;branch=z9hG4bKc95a5f97a7d206629607ef8c25a77fc1;received=211.27.21.53;rport=5060
From: 357108 <sip:357108@mytel.net.au>;tag=4f9d0b6d969ac7b7
To: <sip:96677152@203.166.130.242>;tag=as457ad6f5
Call-ID: 7a85a3772f4969ae81c7c4579d12eb55@211.27.21.53
CSeq: 1755202939 INVITE
User-Agent: Asterisk PBX
Allow: INVITE, ACK, CANCEL, OPTIONS, BYE, REFER, SUBSCRIBE, NOTIFY
Proxy-Authenticate: Digest algorithm=MD5, realm="asterisk", nonce="31e9766d"
Content-Length: 0

2457870mS SipDebugInfo: MZ SIPDialog: ReceiveFromTarget
2457872mS SipDebugInfo: MZ SIPDialog TXN : Decoding of message Succeeded 1
2457872mS SipDebugInfo: SIP: ProcessInbound Message
2457872mS SipDebugInfo: MZ Find End Point 7a85a3772f4969ae81c7c4579d12eb55@211.27.21.53
2457872mS SipDebugInfo: ProcessInboundSIPResponse
2457873mS SipDebugInfo: ExtractRouteFromRecord, entered
2457873mS SipDebugInfo: ExtractContactFromMessage: cannot get From Header 2012
2457873mS SipDebugInfo: MZ SIP-EP: Decoding of 407 (challenge) RESPONSE
2457873mS SipDebugInfo: ProcessAuthenticationRequired: proxy is Digest
2457873mS SipDebugInfo: ProcessWWWAuthenticationRequired: Number of Challenge Param is 3
2457874mS SipDebugInfo: ProcessWWWAuthenticationRequired: realm is "asterisk"
2457874mS SipDebugInfo: ProcessWWWAuthenticationRequired: realm length 10
2457874mS SipDebugInfo: ProcessWWWAuthenticationRequired: nonce is "31e9766d"
2457874mS SipDebugInfo: ProcessWWWAuthenticationRequired: nonce lentgh 10
2457874mS SipDebugInfo: *****
2457874mS SipDebugInfo: State Transition form Old State 1 to New state 17
2457874mS SipDebugInfo: *****
2457874mS SipDebugInfo: *****
2457875mS SipDebugInfo: MZ: ACK SENT TO 203.166.103.242 5060
2457875mS SipDebugInfo: *****
2457876mS SipDebugInfo: MZ: Entered Sip_sendToNetwork packet destination is 203.166.103.242

2457876mS SipDebugInfo: MZ SIPTrunk SendToTarget cba667f2, 5060
2457876mS SIP Trunk: 10:Tx
ACK sip:96677152@203.166.130.242 SIP/2.0
Via: SIP/2.0/UDP 211.27.21.53:5060;rport;branch=z9hG4bKc95a5f97a7d206629607ef8c25a77fc1
From: 357108 <sip:357108@mytel.net.au>;tag=4f9d0b6d969ac7b7
To: <sip:96677152@203.166.130.242>;tag=as457ad6f5
Call-ID: 7a85a3772f4969ae81c7c4579d12eb55@211.27.21.53
CSeq: 1755202939 ACK
Max-Forwards: 70
Allow: INVITE, ACK, CANCEL, OPTIONS, BYE
Content-Length: 0

```

2457876mS SIP Tx: UDP 211.27.21.53:5060 -> 203.166.103.242:5060

ACK sip:96677152@203.166.130.242 SIP/2.0
Via: SIP/2.0/UDP 211.27.21.53:5060;rport;branch=z9hG4bKc95a5f97a7d206629607ef8c25a77fc1
From: 357108 <sip:357108@mytel.net.au>;tag=4f9d0b6d969ac7b7
To: <sip:96677152@203.166.130.242>;tag=as457ad6f5
Call-ID: 7a85a3772f4969ae81c7c4579d12eb55@211.27.21.53
CSeq: 1755202939 ACK
Max-Forwards: 70
Allow: INVITE, ACK, CANCEL, OPTIONS, BYE
Content-Length: 0

2457877mS SipDebugInfo: *****

2457877mS SipDebugInfo: State Transtion form Old State 17 to New state 9

2457877mS SipDebugInfo: *****

2457877mS SipDebugInfo: *****

2457877mS SipDebugInfo: MZ: INVITE SENT TO 203.166.103.242 5060

2457878mS SipDebugInfo: *****

2457878mS SipDebugInfo: building authorisation header

2457879mS SipDebugInfo: MZ: Entered Sip_sendToNetwork packet destination is 203.166.103.242

2457879mS SipDebugInfo: MZ SIPTrunk SendToTarget cba667f2, 5060

2457880mS SIP Tx: UDP 211.27.21.53:5060 -> 203.166.103.242:5060

INVITE sip:96677152@203.166.130.242 SIP/2.0
Via: SIP/2.0/UDP 211.27.21.53:5060;rport;branch=z9hG4bK9d6e438a5d7f9dde0f32c82e9feb1421
From: 357108 <sip:357108@mytel.net.au>;tag=4f9d0b6d969ac7b7
To: <sip:96677152@203.166.130.242>
Call-ID: 7a85a3772f4969ae81c7c4579d12eb55@211.27.21.53
CSeq: 1755202940 INVITE
Contact: 357108 <sip:357108@211.27.21.53:5060;transport=udp>
Max-Forwards: 70
Proxy-Authorization: Digest
username="357108",realm="asterisk",nonce="31e9766d",response="d2df6503c607eba8407d53995ca6fa60",uri="sip:96677152@203.166.130.242"
Content-Type: application/sdp
Content-Length: 300

v=0
o=UserA 2191955339 564929547 IN IP4 211.27.21.53
s=Session SDP
c=IN IP4 211.27.21.53
t=0 0
m=audio 49152 RTP/AVP 18 4 8 0 101
a=rtpmap:18 G729/8000
a=rtpmap:4 G723/8000
a=rtpmap:8 PCMA/8000
a=rtpmap:0 PCMU/8000
a=fmtp:18 annexb = no
a=rtpmap:101 telephone-event/8000
a=fmtp:101 0-15

2457881mS SipDebugInfo: *****

2457881mS SipDebugInfo: State Transtion form Old State 9 to New state 4

2457881mS SipDebugInfo: *****

2457881mS SipDebugInfo: SipTrunks: Cannot free Txn Key 2015

2458116mS SIP Rx: UDP 203.166.103.242:5060 -> 211.27.21.53:5060

SIP/2.0 100 Trying
Via: SIP/2.0/UDP
211.27.21.53:5060;branch=z9hG4bK9d6e438a5d7f9dde0f32c82e9feb1421;received=211.27.21.53;rport=5060
From: 357108 <sip:357108@mytel.net.au>;tag=4f9d0b6d969ac7b7
To: <sip:96677152@203.166.130.242>
Call-ID: 7a85a3772f4969ae81c7c4579d12eb55@211.27.21.53
CSeq: 1755202940 INVITE
User-Agent: Asterisk PBX
Allow: INVITE, ACK, CANCEL, OPTIONS, BYE, REFER, SUBSCRIBE, NOTIFY
Contact: <sip:96677152@203.166.103.242>
Content-Length: 0

2458117mS SIP Trunk: 10:Rx

SIP/2.0 100 Trying
Via: SIP/2.0/UDP
211.27.21.53:5060;branch=z9hG4bK9d6e438a5d7f9dde0f32c82e9feb1421;received=211.27.21.53;rport=5060
From: 357108 <sip:357108@mytel.net.au>;tag=4f9d0b6d969ac7b7
To: <sip:96677152@203.166.130.242>
Call-ID: 7a85a3772f4969ae81c7c4579d12eb55@211.27.21.53
CSeq: 1755202940 INVITE
User-Agent: Asterisk PBX
Allow: INVITE, ACK, CANCEL, OPTIONS, BYE, REFER, SUBSCRIBE, NOTIFY
Contact: <sip:96677152@203.166.103.242>
Content-Length: 0

2458117mS SipDebugInfo: MZ SIPDialog: ReceiveFromTarget
2458118mS SipDebugInfo: MZ SIPDialog TXN : Decoding of message Succeeded 1
2458119mS SipDebugInfo: SIP: ProcessInbound Message
2458119mS SipDebugInfo: MZ Find End Point 7a85a3772f4969ae81c7c4579d12eb55@211.27.21.53
2458119mS SipDebugInfo: ProcessInboundSIPResponse
2458119mS SipDebugInfo: MZ SIPDialog No Tag due to error
2458119mS SipDebugInfo: ExtractRouteFromRecord, entered
2458120mS SipDebugInfo: *****
2458120mS SipDebugInfo: State Transtion form Old State 4 to New state 5
2458120mS SipDebugInfo: *****
2458120mS SipDebugInfo: SipTrunks: Cannot free Txn Key 2015
2458145mS SIP Rx: UDP 203.166.103.242:5060 -> 211.27.21.53:5060

SIP/2.0 183 Session Progress
Via: SIP/2.0/UDP
211.27.21.53:5060;branch=z9hG4bK9d6e438a5d7f9dde0f32c82e9feb1421;received=211.27.21.53;rport=5060
From: 357108 <sip:357108@mytel.net.au>;tag=4f9d0b6d969ac7b7
To: <sip:96677152@203.166.130.242>;tag=as1670caf8
Call-ID: 7a85a3772f4969ae81c7c4579d12eb55@211.27.21.53
CSeq: 1755202940 INVITE
User-Agent: Asterisk PBX
Allow: INVITE, ACK, CANCEL, OPTIONS, BYE, REFER, SUBSCRIBE, NOTIFY
Contact: <sip:96677152@203.166.103.242>
Content-Type: application/sdp
Content-Length: 293

v=0
o=root 25758 25758 IN IP4 203.166.103.242
s=session
c=IN IP4 203.166.103.242
t=0 0
m=audio 10268 RTP/AVP 0 8 18 101
a=rtpmap:0 PCMU/8000
a=rtpmap:8 PCMA/8000
a=rtpmap:18 G729/8000
a=fmtp:18 annexb=no
a=rtpmap:101 telephone-event/8000
a=fmtp:101 0-16
a=silenceSupp:off - - - -

2458145mS SIP Trunk: 10:Rx
SIP/2.0 183 Session Progress
Via: SIP/2.0/UDP
211.27.21.53:5060;branch=z9hG4bK9d6e438a5d7f9dde0f32c82e9feb1421;received=211.27.21.53;rport=5060
From: 357108 <sip:357108@mytel.net.au>;tag=4f9d0b6d969ac7b7
To: <sip:96677152@203.166.130.242>;tag=as1670caf8
Call-ID: 7a85a3772f4969ae81c7c4579d12eb55@211.27.21.53
CSeq: 1755202940 INVITE
User-Agent: Asterisk PBX
Allow: INVITE, ACK, CANCEL, OPTIONS, BYE, REFER, SUBSCRIBE, NOTIFY
Contact: <sip:96677152@203.166.103.242>
Content-Type: application/sdp
Content-Length: 293

v=0
o=root 25758 25758 IN IP4 203.166.103.242
s=session
c=IN IP4 203.166.103.242
t=0 0
m=audio 10268 RTP/AVP 0 8 18 101
a=rtpmap:0 PCMU/8000

a=rtpmap:8 PCMA/8000
a=rtpmap:18 G729/8000
a=fmtp:18 annexb=no
a=rtpmap:101 telephone-event/8000
a=fmtp:101 0-16
a=silenceSupp:off - - -
2458146mS SipDebugInfo: MZ SIPDialog: ReceiveFromTarget
2458148mS SipDebugInfo: MZ SIPDialog TXN : Decoding of message Succeeded 1
2458148mS SipDebugInfo: SIP: ProcessInbound Message
2458149mS SipDebugInfo: MZ Find End Point 7a85a3772f4969ae81c7c4579d12eb55@211.27.21.53
2458149mS SipDebugInfo: ProcessInboundSIPResponse
2458149mS SipDebugInfo: ExtractRouteFromRecord, entered
2458149mS SipDebugInfo: *****
2458149mS SipDebugInfo: State Transtion form Old State 5 to New state 41
2458150mS SipDebugInfo: *****
2458153mS SipDebugInfo: SIPDialog::UpdateSDPState has just transitioned to state 7
2458153mS SipDebugInfo: SipTrunks: Cannot free Txn Key 2015
2458154mS PRN: SetRfc2833 (1): rx payload 101 tx payload 101
2458154mS PRN: SetRfc2833 (1): rx payload 101 tx payload 101
2458155mS PRN: SetRfc2833 (1): rx payload 101 tx payload 101
2459922mS SIP Rx: UDP 203.166.103.242:5060 -> 211.27.21.53:5060

SIP/2.0 180 Ringing
Via: SIP/2.0/UDP
211.27.21.53:5060;branch=z9hG4bK9d6e438a5d7f9dde0f32c82e9feb1421;received=211.27.21.53;rport=5060
From: 357108 <sip:357108@mytel.net.au>;tag=4f9d0b6d969ac7b7
To: <sip:96677152@203.166.130.242>;tag=as1670caf8
Call-ID: 7a85a3772f4969ae81c7c4579d12eb55@211.27.21.53
CSeq: 1755202940 INVITE
User-Agent: Asterisk PBX
Allow: INVITE, ACK, CANCEL, OPTIONS, BYE, REFER, SUBSCRIBE, NOTIFY
Contact: <sip:96677152@203.166.103.242>
Content-Length: 0

2459922mS SIP Trunk: 10:Rx
SIP/2.0 180 Ringing
Via: SIP/2.0/UDP
211.27.21.53:5060;branch=z9hG4bK9d6e438a5d7f9dde0f32c82e9feb1421;received=211.27.21.53;rport=5060
From: 357108 <sip:357108@mytel.net.au>;tag=4f9d0b6d969ac7b7
To: <sip:96677152@203.166.130.242>;tag=as1670caf8
Call-ID: 7a85a3772f4969ae81c7c4579d12eb55@211.27.21.53
CSeq: 1755202940 INVITE
User-Agent: Asterisk PBX
Allow: INVITE, ACK, CANCEL, OPTIONS, BYE, REFER, SUBSCRIBE, NOTIFY
Contact: <sip:96677152@203.166.103.242>
Content-Length: 0

2459922mS SipDebugInfo: MZ SIPDialog: ReceiveFromTarget
2459924mS SipDebugInfo: MZ SIPDialog TXN : Decoding of message Succeeded 1
2459924mS SipDebugInfo: SIP: ProcessInbound Message
2459924mS SipDebugInfo: MZ Find End Point 7a85a3772f4969ae81c7c4579d12eb55@211.27.21.53
2459924mS SipDebugInfo: ProcessInboundSIPResponse
2459925mS SipDebugInfo: ExtractRouteFromRecord, entered
2459925mS SipDebugInfo: SipTrunks: Cannot free Txn Key 2015
2461265mS SIP Rx: UDP 203.166.103.242:5060 -> 211.27.21.53:5060

SIP/2.0 200 OK
Via: SIP/2.0/UDP
211.27.21.53:5060;branch=z9hG4bK9d6e438a5d7f9dde0f32c82e9feb1421;received=211.27.21.53;rport=5060
From: 357108 <sip:357108@mytel.net.au>;tag=4f9d0b6d969ac7b7
To: <sip:96677152@203.166.130.242>;tag=as1670caf8
Call-ID: 7a85a3772f4969ae81c7c4579d12eb55@211.27.21.53
CSeq: 1755202940 INVITE
User-Agent: Asterisk PBX
Allow: INVITE, ACK, CANCEL, OPTIONS, BYE, REFER, SUBSCRIBE, NOTIFY
Contact: <sip:96677152@203.166.103.242>
Content-Type: application/sdp
Content-Length: 293

v=0
o=root 25758 25759 IN IP4 203.166.103.242
s=session

```

c=IN IP4 203.166.103.242
t=0 0
m=audio 10268 RTP/AVP 0 8 18 101
a=rtpmap:0 PCMU/8000
a=rtpmap:8 PCMA/8000
a=rtpmap:18 G729/8000
a=fmtp:18 annexb=no
a=rtpmap:101 telephone-event/8000
a=fmtp:101 0-16
a=silenceSupp:off - - - -
2461265mS SIP Trunk: 10:Rx
SIP/2.0 200 OK
Via: SIP/2.0/UDP
211.27.21.53:5060;branch=z9hG4bK9d6e438a5d7f9dde0f32c82e9feb1421;received=211.27.21.53;rport=5060
From: 357108 <sip:357108@mytel.net.au>;tag=4f9d0b6d969ac7b7
To: <sip:96677152@203.166.130.242>;tag=as1670caf8
Call-ID: 7a85a3772f4969ae81c7c4579d12eb55@211.27.21.53
CSeq: 1755202940 INVITE
User-Agent: Asterisk PBX
Allow: INVITE, ACK, CANCEL, OPTIONS, BYE, REFER, SUBSCRIBE, NOTIFY
Contact: <sip:96677152@203.166.103.242>
Content-Type: application/sdp
Content-Length: 293

v=0
o=root 25758 25759 IN IP4 203.166.103.242
s=session
c=IN IP4 203.166.103.242
t=0 0
m=audio 10268 RTP/AVP 0 8 18 101
a=rtpmap:0 PCMU/8000
a=rtpmap:8 PCMA/8000
a=rtpmap:18 G729/8000
a=fmtp:18 annexb=no
a=rtpmap:101 telephone-event/8000
a=fmtp:101 0-16
a=silenceSupp:off - - - -
2461265mS SipDebugInfo: MZ SIPDialog: ReceiveFromTarget
2461268mS SipDebugInfo: MZ SIPDialog TXN : Decoding of message Succeeded 1
2461268mS SipDebugInfo: SIP: ProcessInbound Message
2461268mS SipDebugInfo: MZ Find End Point 7a85a3772f4969ae81c7c4579d12eb55@211.27.21.53
2461268mS SipDebugInfo: ProcessInboundSIPResponse
2461269mS SipDebugInfo: ExtractRouteFromRecord, entered
2461269mS SipDebugInfo: SIPDialog::UpdateSDPState has just transitioned to state 4
2461269mS SipDebugInfo: *****
2461269mS SipDebugInfo: MZ: ACK SENT TO 203.166.103.242 5060
2461270mS SipDebugInfo: MZ: Entered Sip_sendToNetwork packet destination is 203.166.103.242
2461271mS SipDebugInfo: MZ SIPTrunk SendToTarget cba667f2, 5060
2461271mS SIP Trunk: 10:Tx
ACK sip:96677152@203.166.103.242 SIP/2.0
Via: SIP/2.0/UDP 211.27.21.53:5060;rport;branch=z9hG4bK9d6e438a5d7f9dde0f32c82e9feb1421
From: 357108 <sip:357108@mytel.net.au>;tag=4f9d0b6d969ac7b7
To: <sip:96677152@203.166.130.242>;tag=as1670caf8
Call-ID: 7a85a3772f4969ae81c7c4579d12eb55@211.27.21.53
CSeq: 1755202940 ACK
Max-Forwards: 70
Allow: INVITE, ACK, CANCEL, OPTIONS, BYE
Content-Length: 0

2461271mS SIP Tx: UDP 211.27.21.53:5060 -> 203.166.103.242:5060

ACK sip:96677152@203.166.103.242 SIP/2.0
Via: SIP/2.0/UDP 211.27.21.53:5060;rport;branch=z9hG4bK9d6e438a5d7f9dde0f32c82e9feb1421
From: 357108 <sip:357108@mytel.net.au>;tag=4f9d0b6d969ac7b7
To: <sip:96677152@203.166.130.242>;tag=as1670caf8
Call-ID: 7a85a3772f4969ae81c7c4579d12eb55@211.27.21.53
CSeq: 1755202940 ACK
Max-Forwards: 70
Allow: INVITE, ACK, CANCEL, OPTIONS, BYE
Content-Length: 0

2461272mS SipDebugInfo: SIPDialog::SendCMMMessageFromSDP: 7 attribute fields

```

2461274mS SipDebugInfo:
 *****CMMesage received 11
 2461274mS SipDebugInfo: SDP Outcome is : 1
 2461274mS SipDebugInfo: *****
 2461274mS SipDebugInfo: State Transtion form Old State 41 to New state 16
 2461275mS SipDebugInfo: *****
 2461275mS SipDebugInfo: SIPDialog::UpdateSDPState has just transitioned to state 7
 2461275mS SipDebugInfo: *****
 2461275mS SipDebugInfo: State Transtion form Old State 16 to New state 16
 2461275mS SipDebugInfo: *****
 2461275mS SipDebugInfo: SipTrunks: Cannot free Txn Key 2015
 2465272mS SIP Rx: UDP 203.166.103.242:5060 -> 211.27.21.53:5060

BYE sip:357108@211.27.21.53:5060 SIP/2.0
 Via: SIP/2.0/UDP 203.166.103.242:5060;branch=z9hG4bK754b2313;rport
 From: <sip:96677152@203.166.130.242>;tag=as1670caf8
 To: 357108 <sip:357108@mytel.net.au>;tag=4f9d0b6d969ac7b7
 Contact: <sip:96677152@203.166.103.242>
 Call-ID: 7a85a3772f4969ae81c7c4579d12eb55@211.27.21.53
 CSeq: 102 BYE
 User-Agent: Asterisk PBX
 Max-Forwards: 70
 Content-Length: 0

2465272mS SIP Trunk: 10:Rx
 BYE sip:357108@211.27.21.53:5060 SIP/2.0
 Via: SIP/2.0/UDP 203.166.103.242:5060;branch=z9hG4bK754b2313;rport
 From: <sip:96677152@203.166.130.242>;tag=as1670caf8
 To: 357108 <sip:357108@mytel.net.au>;tag=4f9d0b6d969ac7b7
 Contact: <sip:96677152@203.166.103.242>
 Call-ID: 7a85a3772f4969ae81c7c4579d12eb55@211.27.21.53
 CSeq: 102 BYE
 User-Agent: Asterisk PBX
 Max-Forwards: 70
 Content-Length: 0

2465272mS SipDebugInfo: MZ SIPDialog: ReceiveFromTarget
 2465274mS SipDebugInfo: MZ SIPDialog TXN : Decoding of message Succeeded 1
 2465274mS SipDebugInfo: SIP: ProcessInbound Message
 2465274mS SipDebugInfo: MZ Find End Point 7a85a3772f4969ae81c7c4579d12eb55@211.27.21.53
 2465274mS SipDebugInfo: Process SIP request BYE
 2465274mS SipDebugInfo: Cannot Clone, message does not exist !!!!!!!
 2465275mS SipDebugInfo: SendSIPResponse
 2465275mS SipDebugInfo: SendSIPResponse, Number of Tag Count, 1
 2465275mS SipDebugInfo: MZ: Entered Sip_sendToNetwork packet destination is 203.166.103.242

2465275mS SipDebugInfo: MZ SIPTrunk SendToTarget cba667f2, 5060
 2465276mS SIP Trunk: 10:Tx
 SIP/2.0 200 Ok
 Via: SIP/2.0/UDP 203.166.103.242:5060;branch=z9hG4bK754b2313;rport
 From: <sip:96677152@203.166.130.242>;tag=as1670caf8
 To: 357108 <sip:357108@mytel.net.au>;tag=4f9d0b6d969ac7b7
 Call-ID: 7a85a3772f4969ae81c7c4579d12eb55@211.27.21.53
 CSeq: 102 BYE
 Content-Length: 0

2465276mS SIP Tx: UDP 211.27.21.53:5060 -> 203.166.103.242:5060

SIP/2.0 200 Ok
 Via: SIP/2.0/UDP 203.166.103.242:5060;branch=z9hG4bK754b2313;rport
 From: <sip:96677152@203.166.130.242>;tag=as1670caf8
 To: 357108 <sip:357108@mytel.net.au>;tag=4f9d0b6d969ac7b7
 Call-ID: 7a85a3772f4969ae81c7c4579d12eb55@211.27.21.53
 CSeq: 102 BYE
 Content-Length: 0

2465276mS SipDebugInfo: *****
 2465276mS SipDebugInfo: State Transtion form Old State 16 to New state 22
 2465277mS SipDebugInfo: *****
 2465279mS SipDebugInfo: Call Lost is entered casue is 16, state is 23
 2465279mS SipDebugInfo: SIPDialog destructor ...
 2465279mS SipDebugInfo: SIPDialog - Free SDPBody....

2465280mS SipDebugInfo: Call Lost is about to delete endpoint
2465281mS SipDebugInfo: SipTrunks: Freed Txn Key 2016



Soul Configuration

The testing was conducted on 4.0 Pre Release

Notes:

Soul require the number to be presented to them in International format

Eg: +61296677152 or 611800816818

Soul SIP accounts require that you give them the Public IP address the SIP INVITE will come from, registration is not required because of this, this was the case with the account we were given for testing.

Details given to us by Soul

SIP Server address 125.254.25.2

Note: they have configured the account to only accept sessions from our public IP Address being 203.27.21.53

In-dial Provided 0290074083

See below Screen Shot of the SIP Line 11

The screenshot shows a configuration window titled "SIP Line - Line 11". It contains two main sections: "SIP Line" and "Network Configuration".

Field	Value	Field	Value
Line Number	11	Registration Required	<input type="checkbox"/>
ITSP Domain Name	soulaustralia.com.au	In Service	<input checked="" type="checkbox"/>
ITSP IP Address	125 . 254 . 25 . 2	Use Tel URI	<input type="checkbox"/>
Primary Authentication Name		VoIP Silence Suppression	<input type="checkbox"/>
Primary Authentication Password		Out Of Band DTMF	<input type="checkbox"/>
Primary Registration Expiry	60	Local Tones	<input checked="" type="checkbox"/>
Secondary Authentication Name		Fax T38	<input type="checkbox"/>
Secondary Authentication Password		RE-INVITE Supported	<input checked="" type="checkbox"/>
Secondary Registration Expiry	3600	Voice Packet Size	20
Network Configuration		Compression Mode	G.729(a) 8K CS-ACE
Layer 4 Protocol	UDP	Send Port	5060
Use Network Topology Info	LAN 2	Listen Port	5060

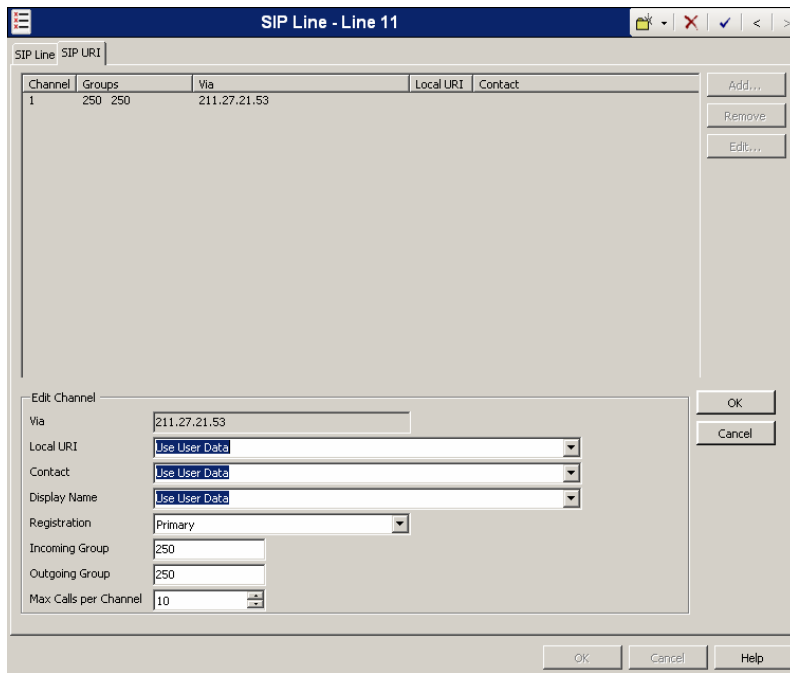

We gave the Line Incoming and Outgoing Group 250
 All Local URI, Contact and Display names were set to "Use User Data"

See below ARS configuration including SIP Short code for 9 numbers; note the required international formatting which is required by Soul

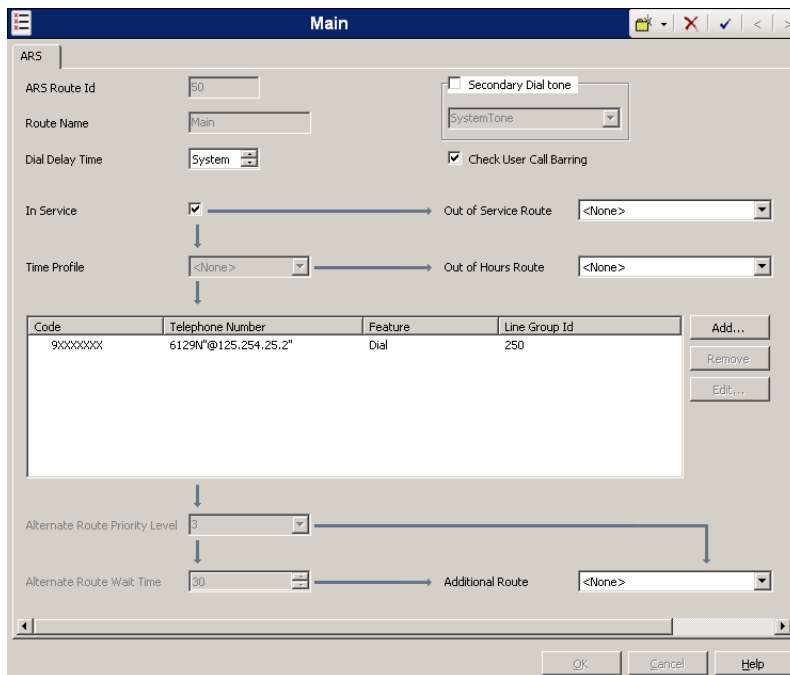

INCOMING CONFIGURATION

The SIP Name on Extn210 was 61290074083 which is the in-dial we were given

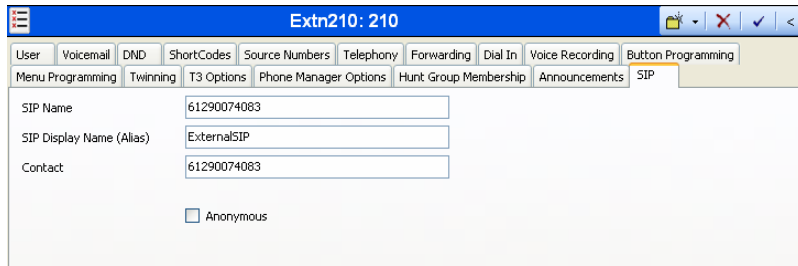

The screenshot shows a configuration window titled "Extn210: 210". It features a menu bar with options: User, Voicemail, DND, ShortCodes, Source Numbers, Telephony, Forwarding, Dial In, Voice Recording, Button Programming, Menu Programming, Twinning, T3 Options, Phone Manager Options, Hunt Group Membership, Announcements, and SIP. The main area contains the following fields:

SIP Name	61290074083
SIP Display Name (Alias)	ExternalSIP
Contact	61290074083
<input type="checkbox"/> Anonymous	

See below incoming call route for Line Group 251, When 0290074083 was dialled the call would route in an ring on Extn210

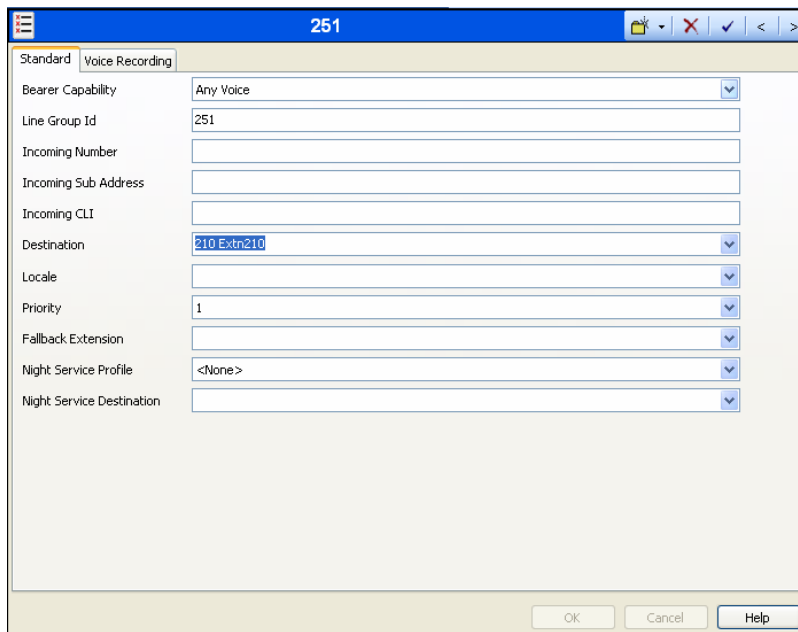

The screenshot shows a configuration window titled "251". It has two tabs: "Standard" and "Voice Recording". The "Standard" tab is active, showing the following configuration:

Bearer Capability	Any Voice
Line Group Id	251
Incoming Number	
Incoming Sub Address	
Incoming CLI	
Destination	210 Extn210
Locale	
Priority	1
Fallback Extension	
Night Service Profile	<None>
Night Service Destination	

At the bottom of the window are buttons for "OK", "Cancel", and "Help".

See below Sys-Monitor trace of Extension 210 to 96677152 via SIP Line 250 as per ARS above

```
4166434mS SipDebugInfo: Timer 4 callback
4166917mS SipDebugInfo: SIPTrunks: Make Target voip, line group id is 250 and ip of cba667f2
4166917mS SipDebugInfo: SIPTrunks cannot find a suitable SIP URI to dial out
4166917mS SipDebugInfo: SIPTrunks: Make Target voip, line group id is 250 and ip of 7dfe1902
4166917mS SipDebugInfo: SIPTrunks: active channels 0 overall number 10
4166918mS SipDebugInfo: License, Valid 1, Available 255, Consumed 0
4166920mS SipDebugInfo: MZ extension is dialing 61296677152@125.254.25.2

4166920mS SipDebugInfo: MZ extension is dialing 61296677152@125.254.25.2
4166920mS SipDebugInfo: *****
4166920mS SipDebugInfo: MZ: INVITE (method) SENT TO 125.254.25.2 5060
4166920mS SipDebugInfo: *****
4166922mS SipDebugInfo: *****
4166922mS SipDebugInfo: MZ: INVITE SENT TO 125.254.25.2 5060
4166922mS SipDebugInfo: *****
4166923mS SipDebugInfo: MZ: Entered Sip_sendToNetwork packet destination is 125.254.25.2

4166923mS SipDebugInfo: MZ SIPTrunk SendToTarget 7dfe1902, 5060
4166923mS SIP Trunk: 11:Tx
INVITE sip:61296677152@125.254.25.2 SIP/2.0
Via: SIP/2.0/UDP 211.27.21.53:5060;rport;branch=z9hG4bKadc5c5ab2bb3541eca3d63acc7052b6a
From: Extn210 <sip:Extn210@soulaustralia.com.au>;tag=160a19c954b9aeb9
To: <sip:61296677152@125.254.25.2>
Call-ID: 96a430d6919ef491e61bbad8fa515d6d@211.27.21.53
CSeq: 1122424747 INVITE
Contact: Extn210 <sip:Extn210@211.27.21.53:5060;transport=udp>
Max-Forwards: 70
Allow: INVITE, ACK, CANCEL, OPTIONS, BYE
Content-Type: application/sdp
Content-Length: 301

v=0
o=UserA 3196822098 1040470160 IN IP4 211.27.21.53
s=Session SDP
c=IN IP4 211.27.21.53
t=0 0
m=audio 49152 RTP/AVP 18 4 8 0 101
a=rtpmap:18 G729/8000
a=rtpmap:4 G723/8000
a=rtpmap:8 PCMA/8000
a=rtpmap:0 PCMU/8000
a=fmtp:18 annexb = no
a=rtpmap:101 telephone-event/8000
a=fmtp:101 0-15
4166923mS SIP Tx: UDP 211.27.21.53:5060 -> 125.254.25.2:5060

INVITE sip:61296677152@125.254.25.2 SIP/2.0
Via: SIP/2.0/UDP 211.27.21.53:5060;rport;branch=z9hG4bKadc5c5ab2bb3541eca3d63acc7052b6a
From: Extn210 <sip:Extn210@soulaustralia.com.au>;tag=160a19c954b9aeb9
To: <sip:61296677152@125.254.25.2>
Call-ID: 96a430d6919ef491e61bbad8fa515d6d@211.27.21.53
CSeq: 1122424747 INVITE
Contact: Extn210 <sip:Extn210@211.27.21.53:5060;transport=udp>
Max-Forwards: 70
Allow: INVITE, ACK, CANCEL, OPTIONS, BYE
Content-Type: application/sdp
Content-Length: 301

v=0
o=UserA 3196822098 1040470160 IN IP4 211.27.21.53
s=Session SDP
c=IN IP4 211.27.21.53
t=0 0
m=audio 49152 RTP/AVP 18 4 8 0 101
a=rtpmap:18 G729/8000
a=rtpmap:4 G723/8000
a=rtpmap:8 PCMA/8000
a=rtpmap:0 PCMU/8000
```

a=fmtp:18 annexb = no
a=rtpmap:101 telephone-event/8000
a=fmtp:101 0-15
4166924mS SipDebugInfo: initialising mTxnContext
4166924mS SipDebugInfo: *****
4166924mS SipDebugInfo: State Transtion form Old State 0 to New state 1
4166924mS SipDebugInfo: *****
4166925mS SipDebugInfo: SIPDialog::UpdateSDPState has just transitioned to state 1
4167064mS SIP Rx: UDP 125.254.25.2:5060 -> 211.27.21.53:5060

SIP/2.0 100 Trying
Via: SIP/2.0/UDP 211.27.21.53:5060;rport;branch=z9hG4bKadc5c5ab2bb3541eca3d63acc7052b6a
From: Extn210 <sip:Extn210@soulaustralia.com.au>;tag=160a19c954b9aeb9
To: <sip:61296677152@125.254.25.2>
Call-ID: 96a430d6919ef491e61bbad8fa515d6d@211.27.21.53
CSeq: 1122424747 INVITE
Content-Length: 0

4167064mS SIP Trunk: 11:Rx
SIP/2.0 100 Trying
Via: SIP/2.0/UDP 211.27.21.53:5060;rport;branch=z9hG4bKadc5c5ab2bb3541eca3d63acc7052b6a
From: Extn210 <sip:Extn210@soulaustralia.com.au>;tag=160a19c954b9aeb9
To: <sip:61296677152@125.254.25.2>
Call-ID: 96a430d6919ef491e61bbad8fa515d6d@211.27.21.53
CSeq: 1122424747 INVITE
Content-Length: 0

4167065mS SipDebugInfo: MZ SIPDialog: ReceiveFromTarget
4167066mS SipDebugInfo: MZ SIPDialog TXN : Decoding of message Succeeded 1
4167066mS SipDebugInfo: SIP: ProcessInbound Message
4167066mS SipDebugInfo: MZ Find End Point 96a430d6919ef491e61bbad8fa515d6d@211.27.21.53
4167066mS SipDebugInfo: ProcessInboundSIPResponse
4167067mS SipDebugInfo: MZ SIPDialog No Tag due to error
4167067mS SipDebugInfo: ExtractRouteFromRecord, entered
4167068mS SipDebugInfo: *****
4167068mS SipDebugInfo: State Transtion form Old State 1 to New state 5
4167069mS SipDebugInfo: *****
4167069mS SipDebugInfo: SipTrunks: Cannot free Txn Key 2015
4168775mS SIP Rx: UDP 125.254.25.2:5060 -> 211.27.21.53:5060

SIP/2.0 180 Ringing
To: <sip:61296677152@125.254.25.2>;tag=3374884284-564851
From: Extn210 <sip:Extn210@soulaustralia.com.au>;tag=160a19c954b9aeb9
Contact: sip:61296677152@125.254.25.2:5060
Call-ID: 96a430d6919ef491e61bbad8fa515d6d@211.27.21.53
CSeq: 1122424747 INVITE
Content-Type: application/sdp
Via: SIP/2.0/UDP 211.27.21.53:5060;rport;branch=z9hG4bKadc5c5ab2bb3541eca3d63acc7052b6a
Content-Length: 227

v=0
o=MSX02-KENT-SYD 1793550 0 IN IP4 125.254.25.2
s=sip call
c=IN IP4 125.254.25.65
t=0 0
m=audio 22252 RTP/AVP 18 101 100
a=fmtp:100 192-194
a=rtpmap:100 X-NSE/8000
a=fmtp:101 0-15
a=rtpmap:101 telephone-event/8000

4168775mS SIP Trunk: 11:Rx
SIP/2.0 180 Ringing
To: <sip:61296677152@125.254.25.2>;tag=3374884284-564851
From: Extn210 <sip:Extn210@soulaustralia.com.au>;tag=160a19c954b9aeb9
Contact: sip:61296677152@125.254.25.2:5060
Call-ID: 96a430d6919ef491e61bbad8fa515d6d@211.27.21.53
CSeq: 1122424747 INVITE
Content-Type: application/sdp
Via: SIP/2.0/UDP 211.27.21.53:5060;rport;branch=z9hG4bKadc5c5ab2bb3541eca3d63acc7052b6a
Content-Length: 227

v=0

o=MSX02-KENT-SYD 1793550 0 IN IP4 125.254.25.2
s=sip call
c=IN IP4 125.254.25.65
t=0 0
m=audio 22252 RTP/AVP 18 101 100
a=fmtp:100 192-194
a=rtpmap:100 X-NSE/8000
a=fmtp:101 0-15
a=rtpmap:101 telephone-event/8000

***** Warning: Missed 1 packet(s) *****

4168778mS SipDebugInfo: MZ SIPDialog TXN : Decoding of message Succeeded 1
4168778mS SipDebugInfo: SIP: ProcessInbound Message
4168778mS SipDebugInfo: MZ Find End Point 96a430d6919ef491e61bbad8fa515d6d@211.27.21.53
4168778mS SipDebugInfo: ProcessInboundSIPResponse
4168779mS SipDebugInfo: ExtractRouteFromRecord, entered
4168779mS SipDebugInfo: *****
4168779mS SipDebugInfo: State Transtion form Old State 5 to New state 41
4168779mS SipDebugInfo: *****
4168779mS SipDebugInfo: SIPDialog::UpdateSDPState has just transitioned to state 4
4168779mS SipDebugInfo: SIPDialog::SendCMMMessageFromSDP: 4 attribute fields
4168782mS SipDebugInfo: SIPDialog::UpdateSDPState has just transitioned to state 7
4168782mS SipDebugInfo: SipTrunks: Cannot free Txn Key 2015
4168783mS PRN: SetRfc2833 (1): rx payload 101 tx payload 101
4168783mS PRN: SetRfc2833 (1): rx payload 101 tx payload 101
4168783mS PRN: SetRfc2833 (1): rx payload 101 tx payload 101
4170832mS SIP Rx: UDP 125.254.25.2:5060 -> 211.27.21.53:5060

SIP/2.0 200 OK
To: <sip:61296677152@125.254.25.2>;tag=3374884284-564851
From: Extn210 <sip:Extn210@soulastralia.com.au>;tag=160a19c954b9aeb9
Contact: sip:61296677152@125.254.25.2:5060
Call-ID: 96a430d6919ef491e61bbad8fa515d6d@211.27.21.53
CSeq: 1122424747 INVITE
Content-Type: application/sdp
Via: SIP/2.0/UDP 211.27.21.53:5060;rport;branch=z9hG4bKadc5c5ab2bb3541eca3d63acc7052b6a
Content-Length: 227

v=0
o=MSX02-KENT-SYD 1793550 0 IN IP4 125.254.25.2
s=sip call
c=IN IP4 125.254.25.65
t=0 0
m=audio 22252 RTP/AVP 18 101 100
a=fmtp:100 192-194
a=rtpmap:100 X-NSE/8000
a=fmtp:101 0-15
a=rtpmap:101 telephone-event/8000

4170832mS SIP Trunk: 11:Rx
SIP/2.0 200 OK
To: <sip:61296677152@125.254.25.2>;tag=3374884284-564851
From: Extn210 <sip:Extn210@soulastralia.com.au>;tag=160a19c954b9aeb9
Contact: sip:61296677152@125.254.25.2:5060
Call-ID: 96a430d6919ef491e61bbad8fa515d6d@211.27.21.53
CSeq: 1122424747 INVITE
Content-Type: application/sdp
Via: SIP/2.0/UDP 211.27.21.53:5060;rport;branch=z9hG4bKadc5c5ab2bb3541eca3d63acc7052b6a
Content-Length: 227

v=0
o=MSX02-KENT-SYD 1793550 0 IN IP4 125.254.25.2
s=sip call
c=IN IP4 125.254.25.65
t=0 0
m=audio 22252 RTP/AVP 18 101 100
a=fmtp:100 192-194
a=rtpmap:100 X-NSE/8000
a=fmtp:101 0-15
a=rtpmap:101 telephone-event/8000

4170833mS SipDebugInfo: MZ SIPDialog: ReceiveFromTarget
4170835mS SipDebugInfo: MZ SIPDialog TXN : Decoding of message Succeeded 1

4170835mS SipDebugInfo: SIP: ProcessInbound Message
4170835mS SipDebugInfo: MZ Find End Point 96a430d6919ef491e61bbad8fa515d6d@211.27.21.53
4170835mS SipDebugInfo: ProcessInboundSIPResponse
4170836mS SipDebugInfo: ExtractRouteFromRecord, entered
4170836mS SipDebugInfo: SIPDialog::UpdateSDPState has just transitioned to state 4
4170836mS SipDebugInfo: *****
4170836mS SipDebugInfo: MZ: ACK SENT TO 125.254.25.2 5060
4170836mS SipDebugInfo: *****
4170837mS SipDebugInfo: MZ: Entered Sip_sendToNetwork packet destination is 125.254.25.2

4170837mS SipDebugInfo: MZ SIPTrunk SendToTarget 7dfe1902, 5060
4170838mS SIP Trunk: 11:Tx
ACK sip:61296677152@125.254.25.2:5060 SIP/2.0
Via: SIP/2.0/UDP 211.27.21.53:5060;rport;branch=z9hG4bKadc5c5ab2bb3541eca3d63acc7052b6a
From: Extn210 <sip:Extn210@soulaustralia.com.au>;tag=160a19c954b9aeb9
To: <sip:61296677152@125.254.25.2>;tag=3374884284-564851
Call-ID: 96a430d6919ef491e61bbad8fa515d6d@211.27.21.53
CSeq: 1122424747 ACK
Max-Forwards: 70
Allow: INVITE, ACK, CANCEL, OPTIONS, BYE
Content-Length: 0

4170838mS SIP Tx: UDP 211.27.21.53:5060 -> 125.254.25.2:5060
ACK sip:61296677152@125.254.25.2:5060 SIP/2.0
Via: SIP/2.0/UDP 211.27.21.53:5060;rport;branch=z9hG4bKadc5c5ab2bb3541eca3d63acc7052b6a
From: Extn210 <sip:Extn210@soulaustralia.com.au>;tag=160a19c954b9aeb9
To: <sip:61296677152@125.254.25.2>;tag=3374884284-564851
Call-ID: 96a430d6919ef491e61bbad8fa515d6d@211.27.21.53
CSeq: 1122424747 ACK
Max-Forwards: 70
Allow: INVITE, ACK, CANCEL, OPTIONS, BYE
Content-Length: 0

4170838mS SipDebugInfo: SIPDialog::SendCMMMessageFromSDP: 4 attribute fields
4170841mS SipDebugInfo:
*****CMMMessage received 11
4170841mS SipDebugInfo: SDP Outcome is : 1
4170841mS SipDebugInfo: *****
4170841mS SipDebugInfo: State Transtion form Old State 41 to New state 16
4170841mS SipDebugInfo: *****
4170841mS SipDebugInfo: SIPDialog::UpdateSDPState has just transitioned to state 7
4170841mS SipDebugInfo: *****
4170842mS SipDebugInfo: State Transtion form Old State 16 to New state 16
4170842mS SipDebugInfo: *****
4170842mS SipDebugInfo: SipTrunks: Cannot free Txn Key 2015
4174046mS SIP Rx: UDP 125.254.25.2:5060 -> 211.27.21.53:5060
BYE sip:Extn210@211.27.21.53:5060;transport=udp SIP/2.0
Max-Forwards: 69
To: Extn210 <sip:Extn210@soulaustralia.com.au>;tag=160a19c954b9aeb9
From: <sip:61296677152@125.254.25.2>;tag=3374884284-564851
Contact: sip:61296677152@125.254.25.2:5060
Call-ID: 96a430d6919ef491e61bbad8fa515d6d@211.27.21.53
CSeq: 2 BYE
Via: SIP/2.0/UDP 125.254.25.2:5060;branch=z9hG4bK8db10656cc434efdf178f007de55e91b
Content-Length: 0

4174046mS SIP Trunk: 11:Rx
BYE sip:Extn210@211.27.21.53:5060;transport=udp SIP/2.0
Max-Forwards: 69
To: Extn210 <sip:Extn210@soulaustralia.com.au>;tag=160a19c954b9aeb9
From: <sip:61296677152@125.254.25.2>;tag=3374884284-564851
Contact: sip:61296677152@125.254.25.2:5060
Call-ID: 96a430d6919ef491e61bbad8fa515d6d@211.27.21.53
CSeq: 2 BYE
Via: SIP/2.0/UDP 125.254.25.2:5060;branch=z9hG4bK8db10656cc434efdf178f007de55e91b
Content-Length: 0

4174046mS SipDebugInfo: MZ SIPDialog: ReceiveFromTarget
4174048mS SipDebugInfo: MZ SIPDialog TXN : Decoding of message Succeeded 1
4174048mS SipDebugInfo: SIP: ProcessInbound Message

4174048mS SipDebugInfo: MZ Find End Point 96a430d6919ef491e61bbad8fa515d6d@211.27.21.53
4174049mS SipDebugInfo: Process SIP request BYE
4174049mS SipDebugInfo: Cannot Clone, message does not exist !!!!!!!
4174049mS SipDebugInfo: SendSIPResponse
4174049mS SipDebugInfo: SendSIPResponse, Number of Tag Count, 1
4174049mS SipDebugInfo: MZ: Entered Sip_sendToNetwork packet destination is 125.254.25.2

4174050mS SipDebugInfo: MZ SIPTrunk SendToTarget 7dfe1902, 5060
4174050mS SIP Trunk: 11:Tx
SIP/2.0 200 Ok
Via: SIP/2.0/UDP 125.254.25.2:5060;branch=z9hG4bK8db10656cc434efdf178f007de55e91b
From: <sip:61296677152@125.254.25.2>;tag=3374884284-564851
To: Extn210 <sip:Extn210@soulaustralia.com.au>;tag=160a19c954b9aeb9
Call-ID: 96a430d6919ef491e61bbad8fa515d6d@211.27.21.53
CSeq: 2 BYE
Content-Length: 0

4174050mS SIP Tx: UDP 211.27.21.53:5060 -> 125.254.25.2:5060

SIP/2.0 200 Ok
Via: SIP/2.0/UDP 125.254.25.2:5060;branch=z9hG4bK8db10656cc434efdf178f007de55e91b
From: <sip:61296677152@125.254.25.2>;tag=3374884284-564851
To: Extn210 <sip:Extn210@soulaustralia.com.au>;tag=160a19c954b9aeb9
Call-ID: 96a430d6919ef491e61bbad8fa515d6d@211.27.21.53
CSeq: 2 BYE
Content-Length: 0

4174051mS SipDebugInfo: *****
4174051mS SipDebugInfo: State Transtion form Old State 16 to New state 22
4174051mS SipDebugInfo: *****
4174053mS SipDebugInfo: Call Lost is entered casue is 16, state is 23
4174053mS SipDebugInfo: SIPDialog destructor ...
4174053mS SipDebugInfo: SIPDialog - Free SDPBody....
4174054mS SipDebugInfo: Call Lost is about to delete endpoint
4174055mS SipDebugInfo: SipTrunks: Freed Txn Key 2016



ISPhone Configuration

The testing was conducted on 4.0 Pre Release

Notes:

ISPhone require the number to be presented to them in International format

Eg: +61296677152 or 611800816818

ISPhone SIP account can be accessed from any public accessible device – Providing authentication details are provided in the call set-up, and the IPO is registered against the SIP Proxy.

Details we were given from the carrier

Username and also incoming number: 61280022329

Password: **XXXXXX (Hidden for Security Reasons)**

Sip server: sip2.isphone.com.au or 203.160.8.74

See blow reflection of IP Office Settings on Line 12

A screenshot of a software configuration window titled "SIP Line - Line 12*". The window has a dark blue header with a small icon on the left and several control icons (a lightbulb, a red X, a blue checkmark, and left/right arrows) on the right. Below the header, there are two tabs: "SIP Line" and "SIP URI". The main area is divided into two columns of settings. The left column contains: "Line Number" (12), "ITSP Domain Name" (isphone.com.au), "ITSP IP Address" (203 . 160 . 8 . 74), "Primary Authentication Name" (61280022329), "Primary Authentication Password" (XXXXXX), "Primary Registration Expiry" (60), "Secondary Authentication Name" (empty), "Secondary Authentication Password" (empty), and "Secondary Registration Expiry" (3600). The right column contains: "Registration Required" (checked), "In Service" (checked), "Use Tel URI" (unchecked), "VoIP Silence Suppression" (unchecked), "Out Of Band DTMF" (unchecked), "Local Tones" (checked), "Fax T38" (unchecked), "RE-INVITE Supported" (checked), "Voice Packet Size" (20), and "Compression Mode" (G.729(a) 8K CS-ACE). At the bottom, there is a "Network Configuration" section with: "Layer 4 Protocol" (UDP), "Use Network Topology Info" (LAN 2), "Send Port" (5060), and "Listen Port" (5060).

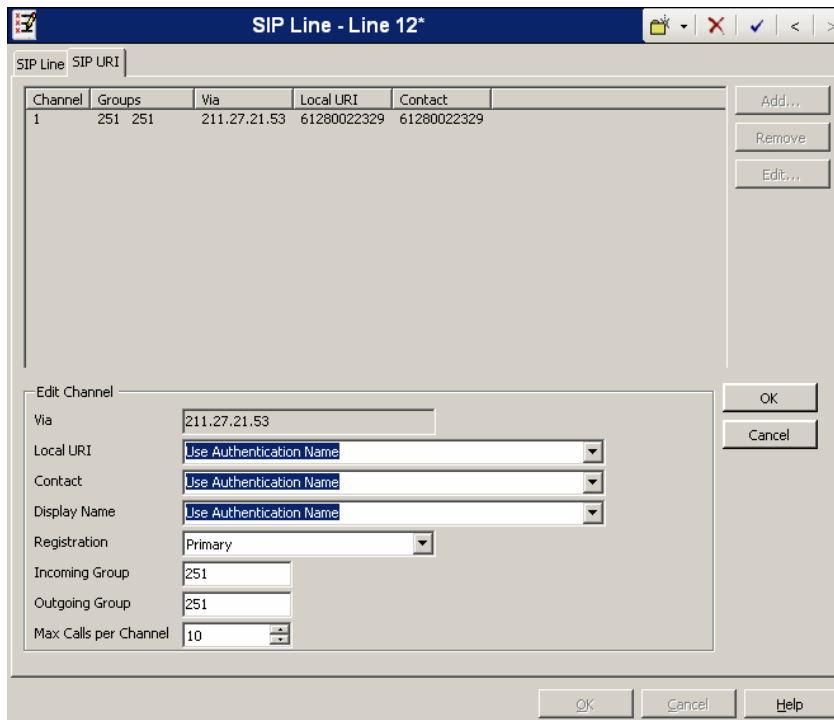

We gave the Line Incoming and Outgoing Group 251
 All Local URI, Contact and Display names were set to "Use Authentication Name"

See below ARS configuration including SIP Short code for 9 numbers

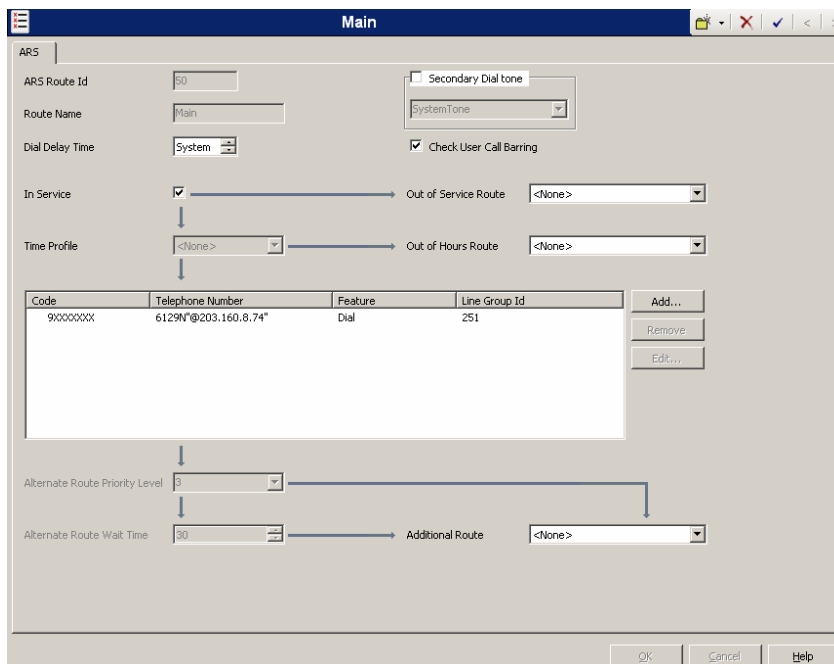

INCOMING CONFIGURATION

251	
Standard	Voice Recording
Bearer Capability	Any Voice
Line Group Id	251
Incoming Number	
Incoming Sub Address	
Incoming CLI	
Destination	210 Extn210
Locale	
Priority	1
Fallback Extension	
Night Service Profile	<None>
Night Service Destination	

See below Sys-Monitor trace of Extension 210 to 96677152 via SIP Line 251 as per ARS above

```
5408843mS SipDebugInfo: SIPTrunks: Make Target voip, line group id is 251 and ip of cba667f2
5408844mS SipDebugInfo: SIPTrunks cannot find a suitable SIP URI to dial out
5408844mS SipDebugInfo: SIPTrunks: Make Target voip, line group id is 251 and ip of 7dfe1902
5408844mS SipDebugInfo: SIPTrunks cannot find a suitable SIP URI to dial out
5408844mS SipDebugInfo: SIPTrunks: Make Target voip, line group id is 251 and ip of cba0084a
5408844mS SipDebugInfo: SIPTrunks: active channels 0 overall number 10
5408844mS SipDebugInfo: License, Valid 1, Available 255, Consumed 0
5408847mS SipDebugInfo: MZ extension is dialing 61296677152@203.160.8.74

5408847mS SipDebugInfo: MZ extension is dialing 61296677152@203.160.8.74
5408847mS SipDebugInfo: *****
5408847mS SipDebugInfo: MZ: INVITE (method) SENT TO 203.160.8.74 5060
5408847mS SipDebugInfo: *****
5408849mS SipDebugInfo: *****
5408849mS SipDebugInfo: MZ: INVITE SENT TO 203.160.8.74 5060
5408849mS SipDebugInfo: *****
5408850mS SipDebugInfo: MZ: Entered Sip_sendToNetwork packet destination is 203.160.8.74

5408850mS SipDebugInfo: MZ SIPTrunk SendToTarget cba0084a, 5060
5408850mS SIP Trunk: 12:Tx
INVITE sip:61296677152@203.160.8.74 SIP/2.0
Via: SIP/2.0/UDP 211.27.21.53:5060;rport;branch=z9hG4bK9272f7391fe31ef5ee55daf1de80eb75
From: 61280022329 <sip:61280022329@isphone.com.au>;tag=af53c7f79391b701
To: <sip:61296677152@203.160.8.74>
Call-ID: 7183d5641f92f6934532a394197975ad@211.27.21.53
CSeq: 1654008671 INVITE
Contact: 61280022329 <sip:61280022329@211.27.21.53:5060;transport=udp>
Max-Forwards: 70
Allow: INVITE, ACK, CANCEL, OPTIONS, BYE
Content-Type: application/sdp
Content-Length: 300

v=0
o=UserA 105622857 1976233741 IN IP4 211.27.21.53
s=Session SDP
c=IN IP4 211.27.21.53
t=0 0
m=audio 49152 RTP/AVP 18 4 8 0 101
a=rtpmap:18 G729/8000
a=rtpmap:4 G723/8000
a=rtpmap:8 PCMA/8000
a=rtpmap:0 PCMU/8000
a=fmtp:18 annexb = no
a=rtpmap:101 telephone-event/8000
a=fmtp:101 0-15
5408850mS SIP Tx: UDP 211.27.21.53:5060 -> 203.160.8.74:5060
```

INVITE sip:61296677152@203.160.8.74 SIP/2.0
Via: SIP/2.0/UDP 211.27.21.53:5060;rport=5060;branch=z9hG4bK9272f7391fe31ef5ee55daf1de80eb75
From: 61280022329 <sip:61280022329@isphone.com.au>;tag=af53c7f79391b701
To: <sip:61296677152@203.160.8.74>
Call-ID: 7183d5641f92f6934532a394197975ad@211.27.21.53
CSeq: 1654008671 INVITE
Contact: 61280022329 <sip:61280022329@211.27.21.53:5060;transport=udp>
Max-Forwards: 70
Allow: INVITE, ACK, CANCEL, OPTIONS, BYE
Content-Type: application/sdp
Content-Length: 300

v=0
o=UserA 105622857 1976233741 IN IP4 211.27.21.53
s=Session SDP
c=IN IP4 211.27.21.53
t=0 0
m=audio 49152 RTP/AVP 18 4 8 0 101
a=rtpmap:18 G729/8000
a=rtpmap:4 G723/8000
a=rtpmap:8 PCMA/8000
a=rtpmap:0 PCMU/8000
a=fmtp:18 annexb = no
a=rtpmap:101 telephone-event/8000
a=fmtp:101 0-15

5408851mS SipDebugInfo: initialising mTxnContext
5408851mS SipDebugInfo: *****
5408851mS SipDebugInfo: State Transtion form Old State 0 to New state 1
5408851mS SipDebugInfo: *****
5408852mS SipDebugInfo: SIPDialog::UpdateSDPState has just transitioned to state 1
5408972mS SIP Rx: UDP 203.160.8.74:5060 -> 211.27.21.53:5060

SIP/2.0 100 trying -- your call is important to us
Via: SIP/2.0/UDP
211.27.21.53:5060;rport=5060;branch=z9hG4bK9272f7391fe31ef5ee55daf1de80eb75
From: 61280022329 <sip:61280022329@isphone.com.au>;tag=af53c7f79391b701
To: <sip:61296677152@203.160.8.74>
Call-ID: 7183d5641f92f6934532a394197975ad@211.27.21.53
CSeq: 1654008671 INVITE
Server: Sip EXpress router (0.9.6 (i386/freebsd))
Content-Length: 0

5408973mS SIP Trunk: 12:Rx
SIP/2.0 100 trying -- your call is important to us
Via: SIP/2.0/UDP
211.27.21.53:5060;rport=5060;branch=z9hG4bK9272f7391fe31ef5ee55daf1de80eb75
From: 61280022329 <sip:61280022329@isphone.com.au>;tag=af53c7f79391b701
To: <sip:61296677152@203.160.8.74>
Call-ID: 7183d5641f92f6934532a394197975ad@211.27.21.53
CSeq: 1654008671 INVITE
Server: Sip EXpress router (0.9.6 (i386/freebsd))
Content-Length: 0

5408973mS SipDebugInfo: MZ SIPDialog: ReceiveFromTarget
5408974mS SipDebugInfo: MZ SIPDialog TXN : Decoding of message Succeeded 1
5408974mS SipDebugInfo: SIP: ProcessInbound Message
5408975mS SipDebugInfo: MZ Find End Point 7183d5641f92f6934532a394197975ad@211.27.21.53
5408975mS SipDebugInfo: ProcessInboundSIPResponse
5408975mS SipDebugInfo: MZ SIPDialog No Tag due to error
5408975mS SipDebugInfo: ExtractRouteFromRecord, entered
5408977mS SipDebugInfo: *****
5408977mS SipDebugInfo: State Transtion form Old State 1 to New state 5
5408977mS SipDebugInfo: *****
5408977mS SipDebugInfo: SipTrunks: Cannot free Txn Key 2015
5408983mS SIP Rx: UDP 203.160.8.74:5060 -> 211.27.21.53:5060

SIP/2.0 401 Unauthorized
Via: SIP/2.0/UDP
211.27.21.53:5060;rport=5060;branch=z9hG4bK9272f7391fe31ef5ee55daf1de80eb75
Record-Route: <sip:203.160.8.74;ftag=af53c7f79391b701;lr>
From: 61280022329 <sip:61280022329@isphone.com.au>;tag=af53c7f79391b701

To: <sip:61296677152@203.160.8.74>
Call-ID: 7183d5641f92f6934532a394197975ad@211.27.21.53
CSeq: 1654008671 INVITE
Server: Sippy
WWW-Authenticate: Digest
realm="203.160.8.74",nonce="c42dafb95f7971fd1db192d2fe141fe6457f66e9"

5408983mS SIP Trunk: 12:Rx
SIP/2.0 401 Unauthorized
Via: SIP/2.0/UDP
211.27.21.53:5060;rport=5060;branch=z9hG4bK9272f7391fe31ef5ee55daf1de80eb75
Record-Route: <sip:203.160.8.74;ftag=af53c7f79391b701;lr>
From: 61280022329 <sip:61280022329@isphone.com.au>;tag=af53c7f79391b701
To: <sip:61296677152@203.160.8.74>
Call-ID: 7183d5641f92f6934532a394197975ad@211.27.21.53
CSeq: 1654008671 INVITE
Server: Sippy
WWW-Authenticate: Digest
realm="203.160.8.74",nonce="c42dafb95f7971fd1db192d2fe141fe6457f66e9"

5408984mS SipDebugInfo: MZ SIPDialog: ReceiveFromTarget
5408985mS SipDebugInfo: MZ SIPDialog TXN : Decoding of message Succeeded 1
5408985mS SipDebugInfo: SIP: ProcessInbound Message
5408985mS SipDebugInfo: MZ Find End Point 7183d5641f92f6934532a394197975ad@211.27.21.53
5408986mS SipDebugInfo: ProcessInboundSIPResponse
5408986mS SipDebugInfo: MZ SIPDialog No Tag due to error
5408986mS SipDebugInfo: ExtractRouteFromRecord, entered
5408986mS SipDebugInfo: LR is On and route is Record-Route: <sip:203.160.8.74;ftag=af53c7f79391b701;lr>

5408987mS SipDebugInfo: ExtractContactFromMessage: cannot get From Header 2012
5408987mS SipDebugInfo: ProcessAuthenticationRequired: www is Digest
5408987mS SipDebugInfo: ProcessWWWAuthenticationRequired: Number of Challenge Param is 2
5408987mS SipDebugInfo: ProcessWWWAuthenticationRequired: realm is "203.160.8.74"
5408987mS SipDebugInfo: ProcessWWWAuthenticationRequired: realm length 14
5408987mS SipDebugInfo: ProcessWWWAuthenticationRequired: nonce is
"c42dafb95f7971fd1db192d2fe141fe6457f66e9"
5408987mS SipDebugInfo: ProcessWWWAuthenticationRequired: nonce length 42
5408988mS SipDebugInfo: *****
5408988mS SipDebugInfo: State Transition form Old State 5 to New state 17
5408988mS SipDebugInfo: *****
5408988mS SipDebugInfo: *****
5408988mS SipDebugInfo: MZ: ACK SENT TO 203.160.8.74 5060
5408988mS SipDebugInfo: *****
5408990mS SipDebugInfo: MZ: Entered Sip_sendToNetwork packet destination is 203.160.8.74

5408990mS SipDebugInfo: MZ SIPTrunk SendToTarget cba0084a, 5060
5408990mS SIP Trunk: 12:Tx
ACK sip:61296677152@203.160.8.74 SIP/2.0
Via: SIP/2.0/UDP 211.27.21.53:5060;rport;branch=z9hG4bK9272f7391fe31ef5ee55daf1de80eb75
Route: <sip:203.160.8.74;ftag=af53c7f79391b701;lr>
From: 61280022329 <sip:61280022329@isphone.com.au>;tag=af53c7f79391b701
To: <sip:61296677152@203.160.8.74>
Call-ID: 7183d5641f92f6934532a394197975ad@211.27.21.53
CSeq: 1654008671 ACK
Max-Forwards: 70
Allow: INVITE, ACK, CANCEL, OPTIONS, BYE
Content-Length: 0

5408990mS SIP Tx: UDP 211.27.21.53:5060 -> 203.160.8.74:5060

ACK sip:61296677152@203.160.8.74 SIP/2.0
Via: SIP/2.0/UDP 211.27.21.53:5060;rport;branch=z9hG4bK9272f7391fe31ef5ee55daf1de80eb75
Route: <sip:203.160.8.74;ftag=af53c7f79391b701;lr>
From: 61280022329 <sip:61280022329@isphone.com.au>;tag=af53c7f79391b701
To: <sip:61296677152@203.160.8.74>
Call-ID: 7183d5641f92f6934532a394197975ad@211.27.21.53
CSeq: 1654008671 ACK
Max-Forwards: 70
Allow: INVITE, ACK, CANCEL, OPTIONS, BYE
Content-Length: 0

5408991mS SipDebugInfo: *****

5408991mS SipDebugInfo: State Transtion form Old State 17 to New state 9
5408991mS SipDebugInfo: *****
5408991mS SipDebugInfo: *****
5408991mS SipDebugInfo: MZ: INVITE SENT TO 203.160.8.74 5060
5408991mS SipDebugInfo: *****
5408992mS SipDebugInfo: building authorisation header
5408993mS SipDebugInfo: MZ: Entered Sip_sendToNetwork packet destination is 203.160.8.74

5408994mS SipDebugInfo: MZ SIPTrunk SendToTarget cba0084a, 5060
5408994mS SIP Trunk: 12:Tx
INVITE sip:61296677152@203.160.8.74 SIP/2.0
Via: SIP/2.0/UDP 211.27.21.53:5060;rport;branch=z9hG4bKeb5fce9f3db6217890dae0145de5243
Route: <sip:203.160.8.74;ftag=af53c7f79391b701;lr>
From: 61280022329 <sip:61280022329@isphone.com.au>;tag=af53c7f79391b701
To: <sip:61296677152@203.160.8.74>
Call-ID: 7183d5641f92f6934532a394197975ad@211.27.21.53
CSeq: 1654008672 INVITE
Contact: 61280022329 <sip:61280022329@211.27.21.53:5060;transport=udp>
Max-Forwards: 70
Authorization: Digest
username="61280022329",realm="203.160.8.74",nonce="c42dafb95f7971fd1db192d2fe141fe6457f66e9",response="79f4fb451dd8ac6ca06d7430dd640c72",uri="sip:61296677152@203.160.8.74"
Content-Type: application/sdp
Content-Length: 300

v=0
o=UserA 105622857 1976233742 IN IP4 211.27.21.53
s=Session SDP
c=IN IP4 211.27.21.53
t=0 0
m=audio 49152 RTP/AVP 18 4 8 0 101
a=rtpmap:18 G729/8000
a=rtpmap:4 G723/8000
a=rtpmap:8 PCMA/8000
a=rtpmap:0 PCMU/8000
a=fmtp:18 annexb = no
a=rtpmap:101 telephone-event/8000
a=fmtp:101 0-15

5408994mS SIP Tx: UDP 211.27.21.53:5060 -> 203.160.8.74:5060

INVITE sip:61296677152@203.160.8.74 SIP/2.0
Via: SIP/2.0/UDP 211.27.21.53:5060;rport;branch=z9hG4bKeb5fce9f3db6217890dae0145de5243
Route: <sip:203.160.8.74;ftag=af53c7f79391b701;lr>
From: 61280022329 <sip:61280022329@isphone.com.au>;tag=af53c7f79391b701
To: <sip:61296677152@203.160.8.74>
Call-ID: 7183d5641f92f6934532a394197975ad@211.27.21.53
CSeq: 1654008672 INVITE
Contact: 61280022329 <sip:61280022329@211.27.21.53:5060;transport=udp>
Max-Forwards: 70
Authorization: Digest
username="61280022329",realm="203.160.8.74",nonce="c42dafb95f7971fd1db192d2fe141fe6457f66e9",response="79f4fb451dd8ac6ca06d7430dd640c72",uri="sip:61296677152@203.160.8.74"
Content-Type: application/sdp
Content-Length: 300

v=0
o=UserA 105622857 1976233742 IN IP4 211.27.21.53
s=Session SDP
c=IN IP4 211.27.21.53
t=0 0
m=audio 49152 RTP/AVP 18 4 8 0 101
a=rtpmap:18 G729/8000
a=rtpmap:4 G723/8000
a=rtpmap:8 PCMA/8000
a=rtpmap:0 PCMU/8000
a=fmtp:18 annexb = no
a=rtpmap:101 telephone-event/8000
a=fmtp:101 0-15

5408995mS SipDebugInfo: *****
5408995mS SipDebugInfo: State Transtion form Old State 9 to New state 4
5408995mS SipDebugInfo: *****
5408995mS SipDebugInfo: SipTrunks: Cannot free Txn Key 2015

5409261mS SIP Rx: UDP 203.160.8.74:5060 -> 211.27.21.53:5060

SIP/2.0 100 trying -- your call is important to us
Via: SIP/2.0/UDP
211.27.21.53:5060;rport=5060;branch=z9hG4bKeb5fcef9f3db6217890dae0145de5243
From: 61280022329 <sip:61280022329@isphone.com.au>;tag=af53c7f79391b701
To: <sip:61296677152@203.160.8.74>
Call-ID: 7183d5641f92f6934532a394197975ad@211.27.21.53
CSeq: 1654008672 INVITE
Server: Sip EXpress router (0.9.6 (i386/freebsd))
Content-Length: 0

5409262mS SIP Trunk: 12:Rx
SIP/2.0 100 trying -- your call is important to us
Via: SIP/2.0/UDP
211.27.21.53:5060;rport=5060;branch=z9hG4bKeb5fcef9f3db6217890dae0145de5243
From: 61280022329 <sip:61280022329@isphone.com.au>;tag=af53c7f79391b701
To: <sip:61296677152@203.160.8.74>
Call-ID: 7183d5641f92f6934532a394197975ad@211.27.21.53
CSeq: 1654008672 INVITE
Server: Sip EXpress router (0.9.6 (i386/freebsd))
Content-Length: 0

5409262mS SipDebugInfo: MZ SIPDialog: ReceiveFromTarget
5409263mS SipDebugInfo: MZ SIPDialog TXN : Decoding of message Succeeded 1
5409263mS SipDebugInfo: SIP: ProcessInbound Message
5409264mS SipDebugInfo: MZ Find End Point 7183d5641f92f6934532a394197975ad@211.27.21.53
5409264mS SipDebugInfo: ProcessInboundSIPResponse
5409264mS SipDebugInfo: MZ SIPDialog No Tag due to error
5409264mS SipDebugInfo: ExtractRouteFromRecord, entered
5409264mS SipDebugInfo: *****
5409265mS SipDebugInfo: State Transtion form Old State 4 to New state 5
5409265mS SipDebugInfo: *****
5409265mS SipDebugInfo: SipTrunks: Cannot free Txn Key 2015
5410915mS SIP Rx: UDP 203.160.8.74:5060 -> 211.27.21.53:5060

SIP/2.0 180 Ringing
Via: SIP/2.0/UDP
211.27.21.53:5060;rport=5060;branch=z9hG4bKeb5fcef9f3db6217890dae0145de5243
Record-Route: <sip:203.160.8.74;ftag=af53c7f79391b701;lr>
From: 61280022329 <sip:61280022329@isphone.com.au>;tag=af53c7f79391b701
To: <sip:61296677152@203.160.8.74>;tag=240689c376cae9623edbbf57954b2521
Call-ID: 7183d5641f92f6934532a394197975ad@211.27.21.53
CSeq: 1654008672 INVITE
Server: Sippy

5410915mS SIP Trunk: 12:Rx
SIP/2.0 180 Ringing
Via: SIP/2.0/UDP
211.27.21.53:5060;rport=5060;branch=z9hG4bKeb5fcef9f3db6217890dae0145de5243
Record-Route: <sip:203.160.8.74;ftag=af53c7f79391b701;lr>
From: 61280022329 <sip:61280022329@isphone.com.au>;tag=af53c7f79391b701
To: <sip:61296677152@203.160.8.74>;tag=240689c376cae9623edbbf57954b2521
Call-ID: 7183d5641f92f6934532a394197975ad@211.27.21.53
CSeq: 1654008672 INVITE
Server: Sippy

5410915mS SipDebugInfo: MZ SIPDialog: ReceiveFromTarget
5410917mS SipDebugInfo: MZ SIPDialog TXN : Decoding of message Succeeded 1
5410917mS SipDebugInfo: SIP: ProcessInbound Message
5410917mS SipDebugInfo: MZ Find End Point 7183d5641f92f6934532a394197975ad@211.27.21.53
5410917mS SipDebugInfo: ProcessInboundSIPResponse
5410918mS SipDebugInfo: ExtractRouteFromRecord, entered
5410918mS SipDebugInfo: ProcessInboundSIPResponse: No Remote Tone
5410919mS SipDebugInfo: SipTrunks: Cannot free Txn Key 2015
5412222mS SIP Rx: UDP 203.160.8.74:5060 -> 211.27.21.53:5060

SIP/2.0 200 OK
Via: SIP/2.0/UDP
211.27.21.53:5060;rport=5060;branch=z9hG4bKeb5fcef9f3db6217890dae0145de5243
Record-Route: <sip:203.160.8.74;ftag=af53c7f79391b701;lr>
From: 61280022329 <sip:61280022329@isphone.com.au>;tag=af53c7f79391b701

To: <sip:61296677152@203.160.8.74>;tag=240689c376cae9623edbbf57954b2521
Call-ID: 7183d5641f92f6934532a394197975ad@211.27.21.53
CSeq: 1654008672 INVITE
Server: Sippy
Contact: Anonymous <sip:203.160.8.74:5061>
Content-Length: 204
Content-Type: application/sdp

v=0
o=Sippy 142412652 1 IN IP4 203.160.8.74
s=VoipCall
t=0 0
m=audio 10602 RTP/AVP 18 101
c=IN IP4 203.160.8.65
a=rtpmap:18 g729/8000/1
a=ptime:20
a=rtpmap:101 telephone-event/8000/1
a=sendrecv

5412225mS SipDebugInfo: MZ SIPDialog TXN : Decoding of message Succeeded 1
5412225mS SipDebugInfo: SIP: ProcessInbound Message
5412225mS SipDebugInfo: MZ Find End Point 7183d5641f92f6934532a394197975ad@211.27.21.53
5412225mS SipDebugInfo: ProcessInboundSIPResponse
5412226mS SipDebugInfo: ExtractRouteFromRecord, entered
5412226mS SipDebugInfo: SIPDialog::UpdateSDPState has just transitioned to state 4
5412226mS SipDebugInfo: *****
5412226mS SipDebugInfo: MZ: ACK SENT TO 203.160.8.74 5060
5412226mS SipDebugInfo: *****
5412228mS SipDebugInfo: MZ: Entered Sip_sendToNetwork packet destination is 203.160.8.74

5412228mS SipDebugInfo: MZ SIPTrunk SendToTarget cba0084a, 5060
5412228mS SIP Trunk: 12:Tx
ACK sip:203.160.8.74:5061 SIP/2.0
Via: SIP/2.0/UDP 211.27.21.53:5060;rport;branch=z9hG4bKeb5fce9f3db6217890dae0145de5243
Route: <sip:203.160.8.74;ftag=af53c7f79391b701;lr>
From: 61280022329 <sip:61280022329@isphone.com.au>;tag=af53c7f79391b701
To: <sip:61296677152@203.160.8.74>;tag=240689c376cae9623edbbf57954b2521
Call-ID: 7183d5641f92f6934532a394197975ad@211.27.21.53
CSeq: 1654008672 ACK
Max-Forwards: 70
Allow: INVITE, ACK, CANCEL, OPTIONS, BYE
Content-Length: 0

5412228mS SIP Tx: UDP 211.27.21.53:5060 -> 203.160.8.74:5060

ACK sip:203.160.8.74:5061 SIP/2.0
Via: SIP/2.0/UDP 211.27.21.53:5060;rport;branch=z9hG4bKeb5fce9f3db6217890dae0145de5243
Route: <sip:203.160.8.74;ftag=af53c7f79391b701;lr>
From: 61280022329 <sip:61280022329@isphone.com.au>;tag=af53c7f79391b701
To: <sip:61296677152@203.160.8.74>;tag=240689c376cae9623edbbf57954b2521
Call-ID: 7183d5641f92f6934532a394197975ad@211.27.21.53
CSeq: 1654008672 ACK
Max-Forwards: 70
Allow: INVITE, ACK, CANCEL, OPTIONS, BYE
Content-Length: 0

5412229mS SipDebugInfo: ProcessInboundSIPResponse: Cannot Get Address From Connection Header 2012
5412229mS SipDebugInfo: SIPDialog::SendCMMMessageFromSDP: 4 attribute fields
5412232mS SipDebugInfo:

*****CMMMessage received 11

5412233mS SipDebugInfo: SDP Outcome is : 1
5412233mS SipDebugInfo: *****
5412233mS SipDebugInfo: State Transtion form Old State 5 to New state 16
5412233mS SipDebugInfo: *****
5412233mS SipDebugInfo: SIPDialog::UpdateSDPState has just transitioned to state 7
5412233mS SipDebugInfo: *****
5412233mS SipDebugInfo: State Transtion form Old State 16 to New state 16
5412233mS SipDebugInfo: *****
5412234mS SipDebugInfo: SipTrunks: Cannot free Txn Key 2015
5412235mS PRN: SetRfc2833 (1): rx payload 101 tx payload 101
5412235mS PRN: SetRfc2833 (1): rx payload 101 tx payload 101

5412236mS PRN: SetRfc2833 (1): rx payload 101 tx payload 101
5415376mS SIP Rx: UDP 203.160.8.74:5060 -> 211.27.21.53:5060

BYE sip:61280022329@211.27.21.53:5060;transport=udp SIP/2.0
Via: SIP/2.0/UDP 203.160.8.74;branch=z9hG4bKdc9c.d16c65ec11ea3776318632d730027476.0
Via: SIP/2.0/UDP

203.160.8.74:5061;branch=z9hG4bK7d24547490b7a9a76d43ed781c84d258;rport=5061
Max-Forwards: 16
From: <sip:61296677152@203.160.8.74>;tag=240689c376cae9623edbbf57954b2521
To: 61280022329 <sip:61280022329@isphone.com.au>;tag=af53c7f79391b701
Call-ID: 7183d5641f92f6934532a394197975ad@211.27.21.53
CSeq: 100 BYE
Contact: Anonymous <sip:203.160.8.74:5061>
Expires: 300
User-Agent: Sippy
cisco-GUID: 1281594991-62460086-222525372-342785982
h323-conf-id: 1281594991-62460086-222525372-342785982

5415376mS SIP Trunk: 12:Rx

BYE sip:61280022329@211.27.21.53:5060;transport=udp SIP/2.0
Via: SIP/2.0/UDP 203.160.8.74;branch=z9hG4bKdc9c.d16c65ec11ea3776318632d730027476.0
Via: SIP/2.0/UDP

203.160.8.74:5061;branch=z9hG4bK7d24547490b7a9a76d43ed781c84d258;rport=5061
Max-Forwards: 16
From: <sip:61296677152@203.160.8.74>;tag=240689c376cae9623edbbf57954b2521
To: 61280022329 <sip:61280022329@isphone.com.au>;tag=af53c7f79391b701
Call-ID: 7183d5641f92f6934532a394197975ad@211.27.21.53
CSeq: 100 BYE
Contact: Anonymous <sip:203.160.8.74:5061>
Expires: 300
User-Agent: Sippy
cisco-GUID: 1281594991-62460086-222525372-342785982
h323-conf-id: 1281594991-62460086-222525372-342785982

5415376mS SipDebugInfo: MZ SIPDialog: ReceiveFromTarget

5415378mS SipDebugInfo: MZ SIPDialog TXN : Decoding of message Succeeded 1

5415379mS SipDebugInfo: SIP: ProcessInbound Message

5415379mS SipDebugInfo: MZ Find End Point 7183d5641f92f6934532a394197975ad@211.27.21.53

5415379mS SipDebugInfo: Process SIP request BYE

5415379mS SipDebugInfo: Cannot Clone, message does not exist !!!!!!!

5415379mS SipDebugInfo: SendSIPResponse

5415380mS SipDebugInfo: SendSIPResponse, Number of Tag Count, 1

5415380mS SipDebugInfo: MZ: Entered Sip_sendToNetwork packet destination is 203.160.8.74

5415380mS SipDebugInfo: MZ SIPTrunk SendToTarget cba0084a, 5060

5415380mS SIP Trunk: 12:Tx

SIP/2.0 200 Ok

Via: SIP/2.0/UDP 203.160.8.74;branch=z9hG4bKdc9c.d16c65ec11ea3776318632d730027476.0

Via: SIP/2.0/UDP

203.160.8.74:5061;branch=z9hG4bK7d24547490b7a9a76d43ed781c84d258;rport=5061
From: <sip:61296677152@203.160.8.74>;tag=240689c376cae9623edbbf57954b2521
To: 61280022329 <sip:61280022329@isphone.com.au>;tag=af53c7f79391b701
Call-ID: 7183d5641f92f6934532a394197975ad@211.27.21.53
CSeq: 100 BYE
Content-Length: 0

5415381mS SIP Tx: UDP 211.27.21.53:5060 -> 203.160.8.74:5060

SIP/2.0 200 Ok

Via: SIP/2.0/UDP 203.160.8.74;branch=z9hG4bKdc9c.d16c65ec11ea3776318632d730027476.0

Via: SIP/2.0/UDP

203.160.8.74:5061;branch=z9hG4bK7d24547490b7a9a76d43ed781c84d258;rport=5061
From: <sip:61296677152@203.160.8.74>;tag=240689c376cae9623edbbf57954b2521
To: 61280022329 <sip:61280022329@isphone.com.au>;tag=af53c7f79391b701
Call-ID: 7183d5641f92f6934532a394197975ad@211.27.21.53
CSeq: 100 BYE
Content-Length: 0

5415381mS SipDebugInfo: *****

5415381mS SipDebugInfo: State Transtion form Old State 16 to New state 22

5415381mS SipDebugInfo: *****

5415383mS SipDebugInfo: Call Lost is entered casue is 16, state is 23

5415384mS SipDebugInfo: SIPDialog destructor ...
5415384mS SipDebugInfo: SIPDialog - Free SDPBody....
5415384mS SipDebugInfo: Call Lost is about to delete endpoint



Engin Configuration

The testing was conducted on 4.0 Pre Release

Notes:

Engin do not require the number to be presented to them in International format
Engin SIP account can be accessed from any public accessible device – Providing authentication retails are provided in the call set-up

The ARS or System Short code must be in the format 029N"@byo.engin.com.au" not 029N"@202.61.13.40"

In the SIP Invite this will make the from field to be the correct format

From: 0282130845 <sip:0282130845@byo.engin.com.au>;tag=516006184bf3f8a4

Details we were given from the carrier

Username and also incoming number: 0282130845

Password: **XXXXXX (Hidden for Security Reasons)**

Sip server: byo.engin.com.au which resolves to 202.61.13.40

See blow reflection of IP Office Settings on Line 13

The screenshot shows a configuration window titled "SIP Line - Line 13*". It contains two main sections: "SIP Line" and "Network Configuration".

Field	Value	Field	Value
Line Number	13	Registration Required	<input checked="" type="checkbox"/>
ITSP Domain Name	byo.engin.com.au	In Service	<input checked="" type="checkbox"/>
ITSP IP Address	202 . 61 . 13 . 40	Use Tel URI	<input type="checkbox"/>
Primary Authentication Name	0282130845	VoIP Silence Suppression	<input type="checkbox"/>
Primary Authentication Password	XXXXXX	Out Of Band DTMF	<input type="checkbox"/>
Primary Registration Expiry	60	Local Tones	<input checked="" type="checkbox"/>
Secondary Authentication Name		Fax T38	<input type="checkbox"/>
Secondary Authentication Password		RE-INWITE Supported	<input checked="" type="checkbox"/>
Secondary Registration Expiry	3600	Voice Packet Size	20
Network Configuration		Compression Mode	G.729(a) 8K CS-ACE
Layer 4 Protocol	UDP	Send Port	5060
Use Network Topology Info	LAN 2	Listen Port	5060

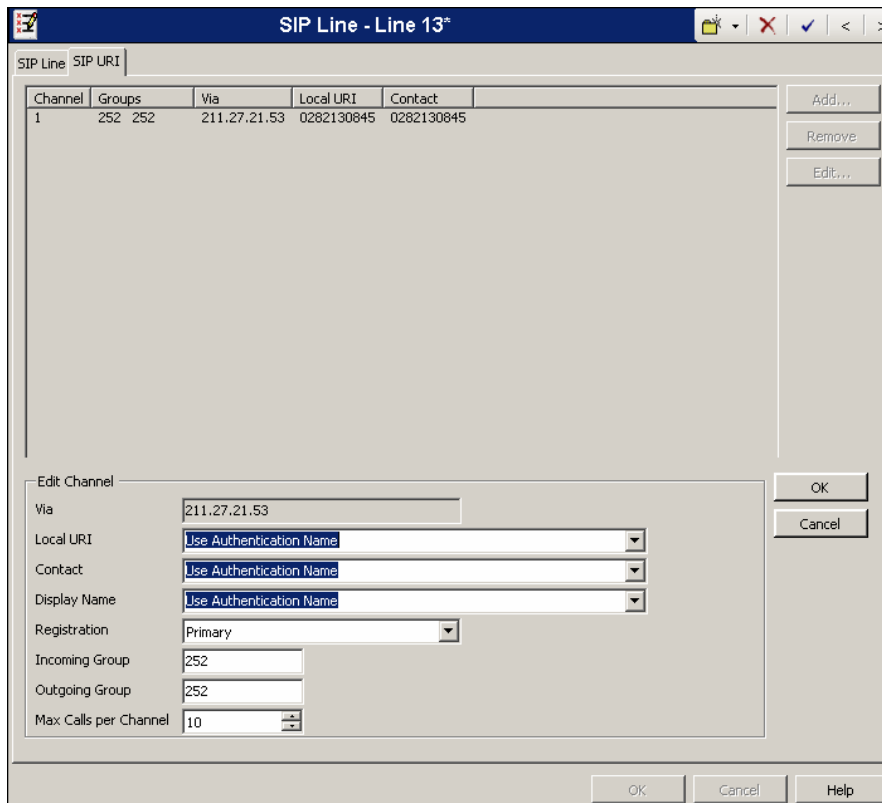

We gave the Line Incoming and Outgoing Group 252
 All Local URI, Contact and Display names were set to "Use Authentication Name"

See below ARS configuration including SIP Short code for 9 numbers Note the specific Short code with domain name

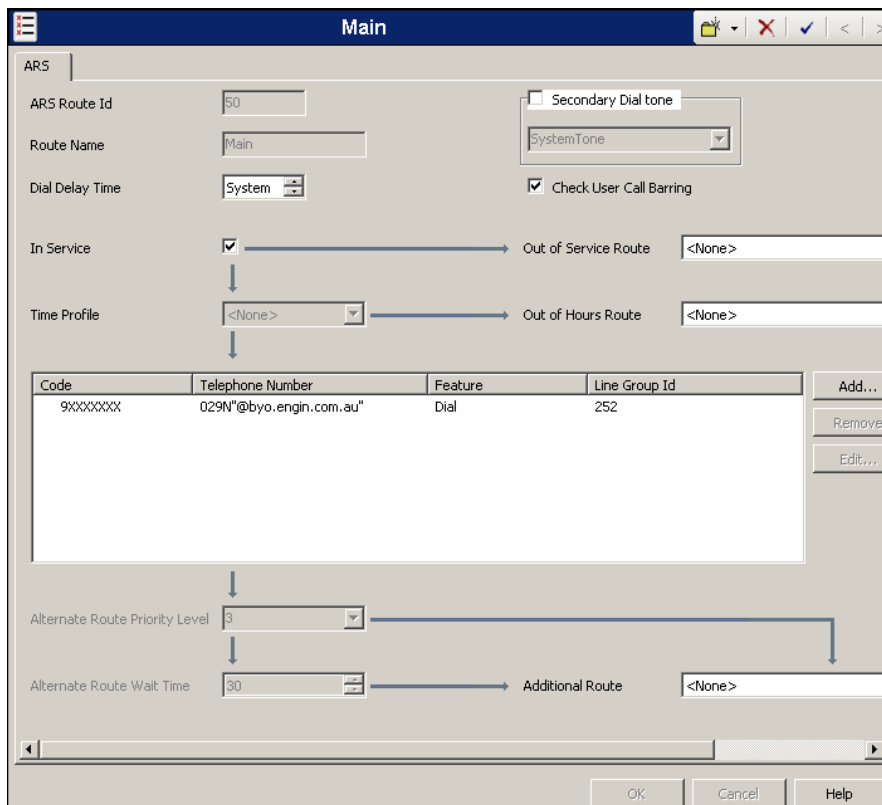

See below Sys-Monitor trace of Extension 210 to 96677152 via SIP Line 252 as per ARS above

```
788250mS SipDebugInfo: SIPTrunks: Make Target voip, line group id is 252 and ip of cba667f2
788250mS SipDebugInfo: SIPTrunks cannot find a suitable SIP URI to dial out
788250mS SipDebugInfo: SIPTrunks: Make Target voip, line group id is 252 and ip of 7dfe1902
788250mS SipDebugInfo: SIPTrunks cannot find a suitable SIP URI to dial out
788250mS SipDebugInfo: SIPTrunks: Make Target voip, line group id is 252 and ip of cba0084a
788251mS SipDebugInfo: SIPTrunks cannot find a suitable SIP URI to dial out
788251mS SipDebugInfo: SIPTrunks: Make Target voip, line group id is 252 and ip of ca3d0d28
788251mS SipDebugInfo: SIPTrunks: active channels 0 overall number 10
788251mS SipDebugInfo: License, Valid 1, Available 255, Consumed 0
788254mS SipDebugInfo: MZ extension is dialing 0296677152@byo.engin.com.au

788254mS SipDebugInfo: MZ extension is dialing 0296677152@byo.engin.com.au
788254mS SipDebugInfo: *****
788254mS SipDebugInfo: MZ: INVITE (method) SENT TO 202.61.13.40 5060
788254mS SipDebugInfo: *****
788256mS SipDebugInfo: *****
788256mS SipDebugInfo: MZ: INVITE SENT TO 202.61.13.40 5060
788256mS SipDebugInfo: *****
788256mS SipDebugInfo: MZ: Entered Sip_sendToNetwork packet destination is 202.61.13.40

788257mS SipDebugInfo: MZ SIPTrunk SendToTarget ca3d0d28, 5060
788257mS SIP Trunk: 13:Tx
INVITE sip:0296677152@byo.engin.com.au SIP/2.0
Via: SIP/2.0/UDP 211.27.21.53:5060;rport;branch=z9hG4bKedacc4f13b8d4daff72178056f35d3f5
From: 0282130845 <sip:0282130845@byo.engin.com.au>;tag=516006184bf3f8a4
To: <sip:0296677152@byo.engin.com.au>
Call-ID: 812a7924a0b3558f375663b9ec87fca@211.27.21.53
CSeq: 2121869255 INVITE
Contact: 0282130845 <sip:0282130845@211.27.21.53:5060;transport=udp>
Max-Forwards: 70
Allow: INVITE, ACK, CANCEL, OPTIONS, BYE
Content-Type: application/sdp
Content-Length: 301

v=0
o=UserA 1847263294 2974457633 IN IP4 211.27.21.53
s=Session SDP
c=IN IP4 211.27.21.53
t=0 0
m=audio 49152 RTP/AVP 18 4 8 0 101
a=rtpmap:18 G729/8000
a=rtpmap:4 G723/8000
a=rtpmap:8 PCMA/8000
a=rtpmap:0 PCMU/8000
a=fmtp:18 annexb = no
a=rtpmap:101 telephone-event/8000
a=fmtp:101 0-15
788257mS SIP Tx: UDP 211.27.21.53:5060 -> 202.61.13.40:5060

INVITE sip:0296677152@byo.engin.com.au SIP/2.0
Via: SIP/2.0/UDP 211.27.21.53:5060;rport;branch=z9hG4bKedacc4f13b8d4daff72178056f35d3f5
From: 0282130845 <sip:0282130845@byo.engin.com.au>;tag=516006184bf3f8a4
To: <sip:0296677152@byo.engin.com.au>
Call-ID: 812a7924a0b3558f375663b9ec87fca@211.27.21.53
CSeq: 2121869255 INVITE
Contact: 0282130845 <sip:0282130845@211.27.21.53:5060;transport=udp>
Max-Forwards: 70
Allow: INVITE, ACK, CANCEL, OPTIONS, BYE
Content-Type: application/sdp
Content-Length: 301

v=0
o=UserA 1847263294 2974457633 IN IP4 211.27.21.53
s=Session SDP
c=IN IP4 211.27.21.53
t=0 0
m=audio 49152 RTP/AVP 18 4 8 0 101
```

a=rtpmap:18 G729/8000
a=rtpmap:4 G723/8000
a=rtpmap:8 PCMA/8000
a=rtpmap:0 PCMU/8000
a=fmtp:18 annexb = no
a=rtpmap:101 telephone-event/8000
a=fmtp:101 0-15
788258mS SipDebugInfo: initialising mTxnContext
788258mS SipDebugInfo: *****
788258mS SipDebugInfo: State Transition form Old State 0 to New state 1
788258mS SipDebugInfo: *****
788258mS SipDebugInfo: SIPDialog::UpdateSDPState has just transitioned to state 1
788405mS SIP Rx: UDP 202.61.13.40:5060 -> 211.27.21.53:5060

SIP/2.0 100 Trying
To: <sip:0296677152@byo.engin.com.au>
From: 0282130845<sip:0282130845@byo.engin.com.au>;tag=516006184bf3f8a4
Via: SIP/2.0/UDP 211.27.21.53:5060;branch=z9hG4bKedacc4f13b8d4daff72178056f35d3f5
Call-ID: 812a7924a0b3558f375663b9ec87fca@211.27.21.53
CSeq: 2121869255 INVITE
Server: DITC-PeerPoint C100/3-05-26-GA7p1
Content-Length: 0

788406mS SIP Trunk: 13:Rx
SIP/2.0 100 Trying
To: <sip:0296677152@byo.engin.com.au>
From: 0282130845<sip:0282130845@byo.engin.com.au>;tag=516006184bf3f8a4
Via: SIP/2.0/UDP 211.27.21.53:5060;branch=z9hG4bKedacc4f13b8d4daff72178056f35d3f5
Call-ID: 812a7924a0b3558f375663b9ec87fca@211.27.21.53
CSeq: 2121869255 INVITE
Server: DITC-PeerPoint C100/3-05-26-GA7p1
Content-Length: 0

788406mS SipDebugInfo: MZ SIPDialog: ReceiveFromTarget
788407mS SipDebugInfo: MZ SIPDialog TXN : Decoding of message Succeeded 1
788407mS SipDebugInfo: SIP: ProcessInbound Message
788408mS SipDebugInfo: MZ Find End Point 812a7924a0b3558f375663b9ec87fca@211.27.21.53
788408mS SipDebugInfo: ProcessInboundSIPResponse
788408mS SipDebugInfo: MZ SIPDialog No Tag due to error
788408mS SipDebugInfo: ExtractRouteFromRecord, entered
788410mS SipDebugInfo: *****
788410mS SipDebugInfo: State Transition form Old State 1 to New state 5
788410mS SipDebugInfo: *****
788410mS SipDebugInfo: SipTrunks: Cannot free Txn Key 2015
788649mS SIP Rx: UDP 202.61.13.40:5060 -> 211.27.21.53:5060

SIP/2.0 407 Proxy Authentication Required
To: <sip:0296677152@voice.mibroadband.com.au>;tag=b0a7f65d
From: 0282130845<sip:0282130845@voice.mibroadband.com.au>;tag=516006184bf3f8a4
Via: SIP/2.0/UDP 211.27.21.53:5060;branch=z9hG4bKedacc4f13b8d4daff72178056f35d3f5
Call-ID: 812a7924a0b3558f375663b9ec87fca@211.27.21.53
CSeq: 2121869255 INVITE
Proxy-Authenticate: Digest
realm="mobileinnovations.com.au",domain="sip:0296677152@byo.engin.com.au",nonce="wY2GQnKHdWsBtaz1tHZ
6vg=_37977",qop="auth"
Content-Length: 0

788650mS SIP Trunk: 13:Rx
SIP/2.0 407 Proxy Authentication Required
To: <sip:0296677152@voice.mibroadband.com.au>;tag=b0a7f65d
From: 0282130845<sip:0282130845@voice.mibroadband.com.au>;tag=516006184bf3f8a4
Via: SIP/2.0/UDP 211.27.21.53:5060;branch=z9hG4bKedacc4f13b8d4daff72178056f35d3f5
Call-ID: 812a7924a0b3558f375663b9ec87fca@211.27.21.53
CSeq: 2121869255 INVITE
Proxy-Authenticate: Digest
realm="mobileinnovations.com.au",domain="sip:0296677152@byo.engin.com.au",nonce="wY2GQnKHdWsBtaz1tHZ
6vg=_37977",qop="auth"
Content-Length: 0

788650mS SipDebugInfo: MZ SIPDialog: ReceiveFromTarget
788652mS SipDebugInfo: MZ SIPDialog TXN : Decoding of message Succeeded 1
788652mS SipDebugInfo: SIP: ProcessInbound Message

788652mS SipDebugInfo: MZ Find End Point 812a7924a0b3558f375663b9ec87fcfa@211.27.21.53
 788652mS SipDebugInfo: ProcessInboundSIPResponse
 788652mS SipDebugInfo: ExtractRouteFromRecord, entered
 788653mS SipDebugInfo: ExtractContactFromMessage: cannot get From Header 2012
 788653mS SipDebugInfo: MZ SIP-EP: Decoding of 407 (challenge) RESPONSE
 788653mS SipDebugInfo: ProcessAuthenticationRequired: proxy is Digest
 788653mS SipDebugInfo: ProcessWWWAuthenticationRequired: Number of Challenge Param is 4
 788653mS SipDebugInfo: ProcessWWWAuthenticationRequired: realm is "mobileinnovations.com.au"
 788653mS SipDebugInfo: ProcessWWWAuthenticationRequired: realm length 26
 788653mS SipDebugInfo: ProcessWWWAuthenticationRequired: nonce is "wY2GQnKHdWsBtaz1tHZ6vg==_37977"
 788654mS SipDebugInfo: ProcessWWWAuthenticationRequired: nonce lentgh 32
 788654mS SipDebugInfo: *****
 788654mS SipDebugInfo: State Transtion form Old State 5 to New state 17
 788654mS SipDebugInfo: *****
 788654mS SipDebugInfo: *****
 788654mS SipDebugInfo: MZ: ACK SENT TO 202.61.13.40 5060
 788654mS SipDebugInfo: *****
 788655mS SipDebugInfo: MZ: Entered Sip_sendToNetwork packet destination is 202.61.13.40

 788656mS SipDebugInfo: MZ SIPTrunk SendToTarget ca3d0d28, 5060
 788656mS SIP Trunk: 13:Tx
 ACK sip:0296677152@byo.engin.com.au SIP/2.0
 Via: SIP/2.0/UDP 211.27.21.53:5060;rport;branch=z9hG4bKedacc4f13b8d4daff72178056f35d3f5
 From: 0282130845 <sip:0282130845@byo.engin.com.au>;tag=516006184bf3f8a4
 To: <sip:0296677152@byo.engin.com.au>;tag=b0a7f65d
 Call-ID: 812a7924a0b3558f375663b9ec87fcfa@211.27.21.53
 CSeq: 2121869255 ACK
 Max-Forwards: 70
 Allow: INVITE, ACK, CANCEL, OPTIONS, BYE
 Content-Length: 0

 788656mS SIP Tx: UDP 211.27.21.53:5060 -> 202.61.13.40:5060

 ACK sip:0296677152@byo.engin.com.au SIP/2.0
 Via: SIP/2.0/UDP 211.27.21.53:5060;rport;branch=z9hG4bKedacc4f13b8d4daff72178056f35d3f5
 From: 0282130845 <sip:0282130845@byo.engin.com.au>;tag=516006184bf3f8a4
 To: <sip:0296677152@byo.engin.com.au>;tag=b0a7f65d
 Call-ID: 812a7924a0b3558f375663b9ec87fcfa@211.27.21.53
 CSeq: 2121869255 ACK
 Max-Forwards: 70
 Allow: INVITE, ACK, CANCEL, OPTIONS, BYE
 Content-Length: 0

 788657mS SipDebugInfo: *****
 788657mS SipDebugInfo: State Transtion form Old State 17 to New state 9
 788657mS SipDebugInfo: *****
 788657mS SipDebugInfo: *****
 788657mS SipDebugInfo: MZ: INVITE SENT TO 202.61.13.40 5060
 788657mS SipDebugInfo: *****
 788658mS SipDebugInfo: building authorisation header
 788659mS SipDebugInfo: MZ: Entered Sip_sendToNetwork packet destination is 202.61.13.40

 788659mS SipDebugInfo: MZ SIPTrunk SendToTarget ca3d0d28, 5060
 788659mS SIP Trunk: 13:Tx
 INVITE sip:0296677152@byo.engin.com.au SIP/2.0
 Via: SIP/2.0/UDP 211.27.21.53:5060;rport;branch=z9hG4bK8d720ac532d5fa78c4664a99fe273ec3
 From: 0282130845 <sip:0282130845@byo.engin.com.au>;tag=516006184bf3f8a4
 To: <sip:0296677152@byo.engin.com.au>
 Call-ID: 812a7924a0b3558f375663b9ec87fcfa@211.27.21.53
 CSeq: 2121869256 INVITE
 Contact: 0282130845 <sip:0282130845@211.27.21.53:5060;transport=udp>
 Max-Forwards: 70
 Proxy-Authorization: Digest
 username="0282130845",realm="mobileinnovations.com.au",nonce="wY2GQnKHdWsBtaz1tHZ6vg==_37977",respo
 nse="df68896ac88c6f81c7e0610a3fde307d",uri="sip:0296677152@byo.engin.com.au"
 Content-Type: application/sdp
 Content-Length: 301

 v=0
 o=UserA 1847263294 2974457634 IN IP4 211.27.21.53
 s=Session SDP
 c=IN IP4 211.27.21.53

t=0 0
m=audio 49152 RTP/AVP 18 4 8 0 101
a=rtpmap:18 G729/8000
a=rtpmap:4 G723/8000
a=rtpmap:8 PCMA/8000
a=rtpmap:0 PCMU/8000
a=fmtp:18 annexb = no
a=rtpmap:101 telephone-event/8000
a=fmtp:101 0-15
788660mS SIP Tx: UDP 211.27.21.53:5060 -> 202.61.13.40:5060

INVITE sip:0296677152@byo.engin.com.au SIP/2.0
Via: SIP/2.0/UDP 211.27.21.53:5060;rport;branch=z9hG4bK8d720ac532d5fa78c4664a99fe273ec3
From: 0282130845 <sip:0282130845@byo.engin.com.au>;tag=516006184bf3f8a4
To: <sip:0296677152@byo.engin.com.au>
Call-ID: 812a7924a0b3558f375663b9ec87fca@211.27.21.53
CSeq: 2121869256 INVITE
Contact: 0282130845 <sip:0282130845@211.27.21.53:5060;transport=udp>
Max-Forwards: 70
Proxy-Authorization: Digest
username="0282130845",realm="mobileinnovations.com.au",nonce="wY2GQnKHdWsBtaz1tHZ6vg==_37977",response="df68896ac88c6f81c7e0610a3fde307d",uri="sip:0296677152@byo.engin.com.au"
Content-Type: application/sdp
Content-Length: 301

v=0
o=UserA 1847263294 2974457634 IN IP4 211.27.21.53
s=Session SDP
c=IN IP4 211.27.21.53
t=0 0
m=audio 49152 RTP/AVP 18 4 8 0 101
a=rtpmap:18 G729/8000
a=rtpmap:4 G723/8000
a=rtpmap:8 PCMA/8000
a=rtpmap:0 PCMU/8000
a=fmtp:18 annexb = no
a=rtpmap:101 telephone-event/8000
a=fmtp:101 0-15
788660mS SipDebugInfo: *****
788661mS SipDebugInfo: State Transition form Old State 9 to New state 4
788661mS SipDebugInfo: *****
788661mS SipDebugInfo: SipTrunks: Cannot free Txn Key 2015
788898mS SIP Rx: UDP 202.61.13.40:5060 -> 211.27.21.53:5060

SIP/2.0 100 Trying
To: <sip:0296677152@byo.engin.com.au>
From: 0282130845<sip:0282130845@byo.engin.com.au>;tag=516006184bf3f8a4
Via: SIP/2.0/UDP 211.27.21.53:5060;branch=z9hG4bK8d720ac532d5fa78c4664a99fe273ec3
Call-ID: 812a7924a0b3558f375663b9ec87fca@211.27.21.53
CSeq: 2121869256 INVITE
Server: DITC-PeerPoint C100/3-05-26-GA7p1
Content-Length: 0

788898mS SIP Trunk: 13:Rx
SIP/2.0 100 Trying
To: <sip:0296677152@byo.engin.com.au>
From: 0282130845<sip:0282130845@byo.engin.com.au>;tag=516006184bf3f8a4
Via: SIP/2.0/UDP 211.27.21.53:5060;branch=z9hG4bK8d720ac532d5fa78c4664a99fe273ec3
Call-ID: 812a7924a0b3558f375663b9ec87fca@211.27.21.53
CSeq: 2121869256 INVITE
Server: DITC-PeerPoint C100/3-05-26-GA7p1
Content-Length: 0

788898mS SipDebugInfo: MZ SIPDialog: ReceiveFromTarget
788899mS SipDebugInfo: MZ SIPDialog TXN : Decoding of message Succeeded 1
788900mS SipDebugInfo: SIP: ProcessInbound Message
788900mS SipDebugInfo: MZ Find End Point 812a7924a0b3558f375663b9ec87fca@211.27.21.53
788900mS SipDebugInfo: ProcessInboundSIPResponse
788900mS SipDebugInfo: MZ SIPDialog No Tag due to error
788900mS SipDebugInfo: ExtractRouteFromRecord, entered
788901mS SipDebugInfo: *****
788901mS SipDebugInfo: State Transition form Old State 4 to New state 5

788901mS SipDebugInfo: *****
788901mS SipDebugInfo: SipTrunks: Cannot free Txn Key 2015
790760mS SIP Rx: UDP 202.61.13.40:5060 -> 211.27.21.53:5060

SIP/2.0 180 Ringing
To: <sip:0296677152@voice.mibroadband.com.au>;tag=fe9f437f
From: 0282130845<sip:0282130845@voice.mibroadband.com.au>;tag=516006184bf3f8a4
Via: SIP/2.0/UDP 211.27.21.53:5060;branch=z9hG4bK8d720ac532d5fa78c4664a99fe273ec3
Call-ID: 812a7924a0b3558f375663b9ec87fca@211.27.21.53
CSeq: 2121869256 INVITE
Contact: <sip:0C7Z2psXivb_tdhTsGXHaY8gJy89-uwH8IGAufQ@202.61.13.40:5060>
Allow: INVITE, OPTIONS, BYE, CANCEL, ACK, REFER, SUBSCRIBE, NOTIFY, INFO, REGISTER
Date: Thu, 14 Dec 2006 04:33:48 GMT
Server: Cisco-SIPGateway/IOS-12.x
Allow-Events: telephone-event
Content-Length: 0

790761mS SIP Trunk: 13:Rx
SIP/2.0 180 Ringing
To: <sip:0296677152@voice.mibroadband.com.au>;tag=fe9f437f
From: 0282130845<sip:0282130845@voice.mibroadband.com.au>;tag=516006184bf3f8a4
Via: SIP/2.0/UDP 211.27.21.53:5060;branch=z9hG4bK8d720ac532d5fa78c4664a99fe273ec3
Call-ID: 812a7924a0b3558f375663b9ec87fca@211.27.21.53
CSeq: 2121869256 INVITE
Contact: <sip:0C7Z2psXivb_tdhTsGXHaY8gJy89-uwH8IGAufQ@202.61.13.40:5060>
Allow: INVITE, OPTIONS, BYE, CANCEL, ACK, REFER, SUBSCRIBE, NOTIFY, INFO, REGISTER
Date: Thu, 14 Dec 2006 04:33:48 GMT
Server: Cisco-SIPGateway/IOS-12.x
Allow-Events: telephone-event
Content-Length: 0

790761mS SipDebugInfo: MZ SIPDialog: ReceiveFromTarget
790763mS SipDebugInfo: MZ SIPDialog TXN : Decoding of message Succeeded 1
790763mS SipDebugInfo: SIP: ProcessInbound Message
790763mS SipDebugInfo: MZ Find End Point 812a7924a0b3558f375663b9ec87fca@211.27.21.53
790763mS SipDebugInfo: ProcessInboundSIPResponse
790764mS SipDebugInfo: ExtractRouteFromRecord, entered
790764mS SipDebugInfo: ProcessInboundSIPResponse: No Remote Tone
790765mS SipDebugInfo: SipTrunks: Cannot free Txn Key 2015
791687mS SIP Rx: UDP 202.61.13.40:5060 -> 211.27.21.53:5060

SIP/2.0 200 OK
To: <sip:0296677152@voice.mibroadband.com.au>;tag=fe9f437f
From: 0282130845<sip:0282130845@voice.mibroadband.com.au>;tag=516006184bf3f8a4
Via: SIP/2.0/UDP 211.27.21.53:5060;branch=z9hG4bK8d720ac532d5fa78c4664a99fe273ec3
Call-ID: 812a7924a0b3558f375663b9ec87fca@211.27.21.53
CSeq: 2121869256 INVITE
Contact: <sip:0C7Z2psXivb_tdhTsGXHaY8gJy89-uwH8IGAufQ@202.61.13.40:5060>
Allow: INVITE, OPTIONS, BYE, CANCEL, ACK, REFER, SUBSCRIBE, NOTIFY, INFO, REGISTER
Content-Disposition: session;handling=required
Content-Type: application/sdp
Date: Thu, 14 Dec 2006 04:33:48 GMT
Server: Cisco-SIPGateway/IOS-12.x
Allow-Events: telephone-event
Content-Length: 265

v=0
o=CiscoSystemsSIP-GW-UserAgent 9211 1094264623 IN IP4 202.61.13.40
s=SIP Call
c=IN IP4 202.61.13.40
t=0 0
m=audio 18290 RTP/AVP 18 101
c=IN IP4 202.61.13.40
a=fmtp:18 annexb=yes
a=fmtp:101 0-15
a=rtpmap:18 G729/8000
a=rtpmap:101 telephone-event/8000

791687mS SIP Trunk: 13:Rx
SIP/2.0 200 OK
To: <sip:0296677152@voice.mibroadband.com.au>;tag=fe9f437f
From: 0282130845<sip:0282130845@voice.mibroadband.com.au>;tag=516006184bf3f8a4
Via: SIP/2.0/UDP 211.27.21.53:5060;branch=z9hG4bK8d720ac532d5fa78c4664a99fe273ec3

Call-ID: 812a7924a0b3558f375663b9ec87fcfa@211.27.21.53
CSeq: 2121869256 INVITE
Contact: <sip:0C7Z2psXivb_tdhTsGXHaY8gJy89-uwh8lGAufQ@202.61.13.40:5060>
Allow: INVITE, OPTIONS, BYE, CANCEL, ACK, REFER, SUBSCRIBE, NOTIFY, INFO, REGISTER
Content-Disposition: session;handling=required
Content-Type: application/sdp
Date: Thu, 14 Dec 2006 04:33:48 GMT
Server: Cisco-SIPGateway/IOS-12.x
Allow-Events: telephone-event
Content-Length: 265

v=0
o=CiscoSystemsSIP-GW-UserAgent 9211 1094264623 IN IP4 202.61.13.40
s=SIP Call
c=IN IP4 202.61.13.40
t=0 0
m=audio 18290 RTP/AVP 18 101
c=IN IP4 202.61.13.40
a=fmtp:18 annexb=yes
a=fmtp:101 0-15
a=rtpmap:18 G729/8000
a=rtpmap:101 telephone-event/8000

791687mS SipDebugInfo: MZ SIPDialog: ReceiveFromTarget
791690mS SipDebugInfo: MZ SIPDialog TXN : Decoding of message Succeeded 1
791690mS SipDebugInfo: SIP: ProcessInbound Message
791691mS SipDebugInfo: MZ Find End Point 812a7924a0b3558f375663b9ec87fcfa@211.27.21.53
791691mS SipDebugInfo: ProcessInboundSIPResponse
791691mS SipDebugInfo: ExtractRouteFromRecord, entered
791691mS SipDebugInfo: SIPDialog::UpdateSDPState has just transitioned to state 4
791692mS SipDebugInfo: *****
791692mS SipDebugInfo: MZ: ACK SENT TO 202.61.13.40 5060
791692mS SipDebugInfo: *****
791693mS SipDebugInfo: MZ: Entered Sip_sendToNetwork packet destination is 202.61.13.40

791693mS SipDebugInfo: MZ SIPTrunk SendToTarget ca3d0d28, 5060
791693mS SIP Trunk: 13:Tx
ACK sip:0C7Z2psXivb_tdhTsGXHaY8gJy89-uwh8lGAufQ@202.61.13.40:5060 SIP/2.0
Via: SIP/2.0/UDP 211.27.21.53:5060;rport;branch=z9hG4bK8d720ac532d5fa78c4664a99fe273ec3
From: 0282130845 <sip:0282130845@byo.engin.com.au>;tag=516006184bf3f8a4
To: <sip:0296677152@byo.engin.com.au>;tag=fe9f437f
Call-ID: 812a7924a0b3558f375663b9ec87fcfa@211.27.21.53
CSeq: 2121869256 ACK
Max-Forwards: 70
Allow: INVITE, ACK, CANCEL, OPTIONS, BYE
Content-Length: 0

791693mS SIP Tx: UDP 211.27.21.53:5060 -> 202.61.13.40:5060

ACK sip:0C7Z2psXivb_tdhTsGXHaY8gJy89-uwh8lGAufQ@202.61.13.40:5060 SIP/2.0
Via: SIP/2.0/UDP 211.27.21.53:5060;rport;branch=z9hG4bK8d720ac532d5fa78c4664a99fe273ec3
From: 0282130845 <sip:0282130845@byo.engin.com.au>;tag=516006184bf3f8a4
To: <sip:0296677152@byo.engin.com.au>;tag=fe9f437f
Call-ID: 812a7924a0b3558f375663b9ec87fcfa@211.27.21.53
CSeq: 2121869256 ACK
Max-Forwards: 70
Allow: INVITE, ACK, CANCEL, OPTIONS, BYE
Content-Length: 0

791694mS SipDebugInfo: SIPDialog::SendCMMMessageFromSDP: 4 attribute fields
791697mS SipDebugInfo:
*****CMMMessage received 11
791698mS SipDebugInfo: SDP Outcome is : 1
791698mS SipDebugInfo: *****
791698mS SipDebugInfo: State Transtion form Old State 5 to New state 16
791698mS SipDebugInfo: *****
791698mS SipDebugInfo: SIPDialog::UpdateSDPState has just transitioned to state 7
791698mS SipDebugInfo: *****
791698mS SipDebugInfo: State Transtion form Old State 16 to New state 16
791698mS SipDebugInfo: *****
791699mS SipDebugInfo: SipTrunks: Cannot free Txn Key 2015
793232mS SIP Rx: UDP 202.61.13.40:5060 -> 211.27.21.53:5060

BYE sip:0282130845@211.27.21.53:5060;transport=udp SIP/2.0
To: 0282130845<sip:0282130845@voice.mibroadband.com.au>;tag=516006184bf3f8a4
From: <sip:0296677152@voice.mibroadband.com.au>;tag=fe9f437f
Via: SIP/2.0/UDP 202.61.13.40:5060;branch=z9hG4bK-d87543-5981e0239adf6822d8fd-1-
cHA5MTQ0Nzk3NTY1NDc4ZTY0Mmwy2OQ...-d87543-
Call-ID: 812a7924a0b3558f375663b9ec87fca@211.27.21.53
CSeq: 17308047 BYE
Contact: <sip:0C7Z2psXivb_tdhTsGXHaY8gJy89-uwh8lGAufQ@202.61.13.40:5060>
Max-Forwards: 68
Date: Thu, 14 Dec 2006 04:33:50 GMT
Timestamp: 1166070832
User-Agent: Cisco-SIPGateway/IOS-12.x
Content-Length: 0
Reason: Q.850;cause=16

793232mS SIP Trunk: 13:Rx
BYE sip:0282130845@211.27.21.53:5060;transport=udp SIP/2.0
To: 0282130845<sip:0282130845@voice.mibroadband.com.au>;tag=516006184bf3f8a4
From: <sip:0296677152@voice.mibroadband.com.au>;tag=fe9f437f
Via: SIP/2.0/UDP 202.61.13.40:5060;branch=z9hG4bK-d87543-5981e0239adf6822d8fd-1-
cHA5MTQ0Nzk3NTY1NDc4ZTY0Mmwy2OQ...-d87543-
Call-ID: 812a7924a0b3558f375663b9ec87fca@211.27.21.53
CSeq: 17308047 BYE
Contact: <sip:0C7Z2psXivb_tdhTsGXHaY8gJy89-uwh8lGAufQ@202.61.13.40:5060>
Max-Forwards: 68
Date: Thu, 14 Dec 2006 04:33:50 GMT
Timestamp: 1166070832
User-Agent: Cisco-SIPGateway/IOS-12.x
Content-Length: 0
Reason: Q.850;cause=16

793233mS SipDebugInfo: MZ SIPDialog: ReceiveFromTarget
793235mS SipDebugInfo: MZ SIPDialog TXN : Decoding of message Succeeded 1
793235mS SipDebugInfo: SIP: ProcessInbound Message
793235mS SipDebugInfo: MZ Find End Point 812a7924a0b3558f375663b9ec87fca@211.27.21.53
793236mS SipDebugInfo: Process SIP request BYE
793236mS SipDebugInfo: Cannot Clone, message does not exist !!!!!!!
793236mS SipDebugInfo: SendSIPResponse
793236mS SipDebugInfo: SendSIPResponse, Number of Tag Count, 1
793237mS SipDebugInfo: MZ: Entered Sip_sendToNetwork packet destination is 202.61.13.40

793237mS SipDebugInfo: MZ SIPTrunk SendToTarget ca3d0d28, 5060
793237mS SIP Trunk: 13:Tx
SIP/2.0 200 Ok
Via: SIP/2.0/UDP 202.61.13.40:5060;branch=z9hG4bK-d87543-5981e0239adf6822d8fd-1-
cHA5MTQ0Nzk3NTY1NDc4ZTY0Mmwy2OQ...-d87543-
From: <sip:0296677152@voice.mibroadband.com.au>;tag=fe9f437f
To: 0282130845 <sip:0282130845@voice.mibroadband.com.au>;tag=516006184bf3f8a4
Call-ID: 812a7924a0b3558f375663b9ec87fca@211.27.21.53
CSeq: 17308047 BYE
Content-Length: 0

793237mS SIP Tx: UDP 211.27.21.53:5060 -> 202.61.13.40:5060

SIP/2.0 200 Ok
Via: SIP/2.0/UDP 202.61.13.40:5060;branch=z9hG4bK-d87543-5981e0239adf6822d8fd-1-
cHA5MTQ0Nzk3NTY1NDc4ZTY0Mmwy2OQ...-d87543-
From: <sip:0296677152@voice.mibroadband.com.au>;tag=fe9f437f
To: 0282130845 <sip:0282130845@voice.mibroadband.com.au>;tag=516006184bf3f8a4
Call-ID: 812a7924a0b3558f375663b9ec87fca@211.27.21.53
CSeq: 17308047 BYE
Content-Length: 0

793238mS SipDebugInfo: *****
793238mS SipDebugInfo: State Transtion form Old State 16 to New state 22
793238mS SipDebugInfo: *****
793240mS SipDebugInfo: Call Lost is entered casue is 16, state is 23
793240mS SipDebugInfo: SIPDialog destructor ...
793240mS SipDebugInfo: SIPDialog - Free SDPBody....
793241mS SipDebugInfo: Call Lost is about to delete endpoint
793242mS SipDebugInfo: SipTrunks: Freed Txn Key 2016

Other Useful SIP related Information

SIP Response Codes

SIP response codes, class 1: Provisional messages

These are sent within a SIP dialogue

- 100 Trying
- 180 Ringing
- 181 Call Is Being Forwarded
- 182 Queued
- 183 Session Progress

SIP Response codes: 2xx class

The 2xx class of responses indicates a success

- 200 OK
- 202 accepted: *Used for referrals*

SIP response codes, class 3xx

The 3xx class of responses indicates a redirection of the call

- 300 Multiple Choices
- 301 Moved Permanently
- 302 Moved Temporarily
- 305 Use Proxy
- 380 Alternative Service

SIP responses, class 4: Request failures

- 400 Bad Request
- 401 Unauthorized: *Used only by registrars. Proxys should use proxy authorization 407*
- 402 Payment Required (Reserved for future use)
- 403 Forbidden
- 404 Not Found: *User not found*
- 405 Method Not Allowed
- 406 Not Acceptable
- 407 Proxy Authentication Required
- 408 Request Timeout: *Couldn't find the user in time*
- 410 Gone: *The user existed once, but is not available here any more.*
- 413 Request Entity Too Large
- 414 Request-URI Too Long
- 415 Unsupported Media Type
- 416 Unsupported URI Scheme
- 420 Bad Extension: *Bad SIP Protocol Extension used, not understood by the server*
- 421 Extension Required
- 423 Interval Too Brief
- 480 Temporarily Unavailable
- 481 Call/Transaction Does Not Exist
- 482 Loop Detected
- 483 Too Many Hops
- 484 Address Incomplete

- 485 Ambiguous
- 486 Busy Here
- 487 Request Terminated
- 488 Not Acceptable Here
- 491 Request Pending
- 493 Undecipherable: *Could not decrypt S/MIME body part*

SIP responses, class 5: Server failures

- 500 Server Internal Error
- 501 Not Implemented: *The SIP request method is not implemented here*
- 502 Bad Gateway
- 503 Service Unavailable
- 504 Server Time-out
- 505 Version Not Supported: *The server does not support this version of the SIP protocol*
- 513 Message Too Large

SIP response codes, class 6: Global failures

- 600 Busy Everywhere
- 603 Decline
- 604 Does Not Exist Anywhere
- 606 Not Acceptable

Sample SIP Transactions

Register Transaction

The UA sends a REGISTER message to the Registrar. The REGISTER message contains the UA's SIP URI and the current contact address from which the UA is registering. The Registrar responds with a 200 OK response.

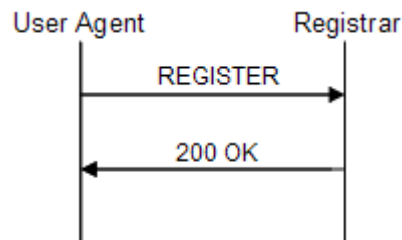

Session Invitation and Termination Transactions

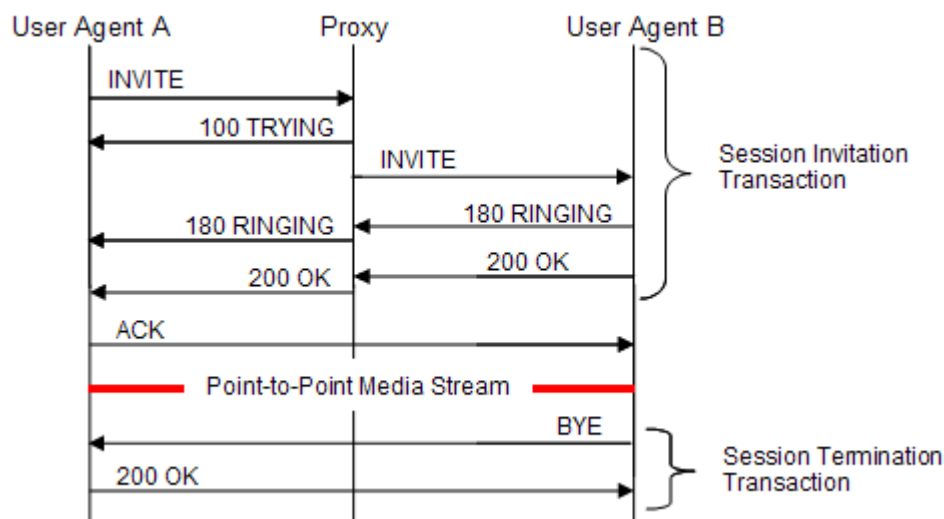

In the transactions above, a UA sends an INVITE request to another UA via a proxy. The proxy immediately replies with a 100 TRYING response, and then forwards the INVITE on to the called UA. (Note that the requests and responses may actually traverse several proxies, which are not shown in the diagram for the purpose of simplification.) The called UA sends a 180 RINGING response back through the proxy, followed by a 200 OK response. The calling UA receives the 200 OK and responds with an ACK message. Then, a direct media stream is established between the UAs, using RTP or another media transport protocol. From this point on, the UAs communicate directly without going through a proxy (although any proxy in the initial signalling path can choose to remain in the signalling path for the rest of the call).

Event Subscription and Notification Transactions

User Agents use the SUBSCRIBE message to request current state information (presence) about another User Agent. After the User Agent sends a SUBSCRIBE request, the proxy replies with a 200 OK followed by a NOTIFY. The User Agent replies with a 200 OK. After that point, the proxy sends a NOTIFY any time there is a change in status of the event to which the user has subscribed.

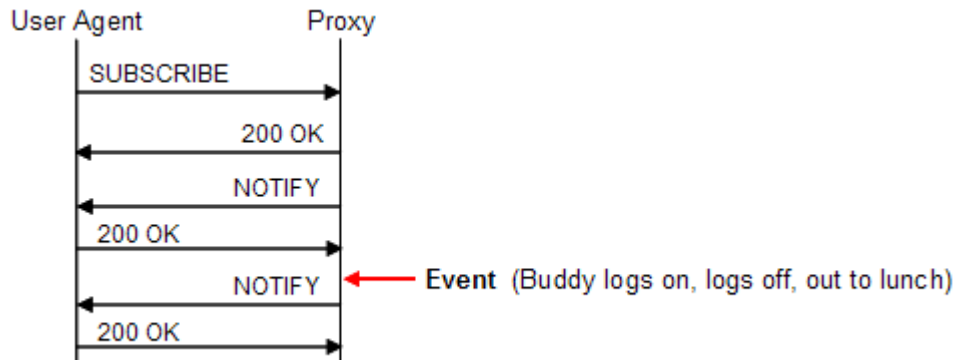

Instant Message Transactions

User Agent A sends a MESSAGE request through a proxy to establish an instant messaging session. The actual message text is included in the body of the MESSAGE request. User Agent B responds with a 200 OK, and then sends a MESSAGE request with IM text. User Agent A responds with a 200 OK.

