

Australian United Sportdog Clubs

Guidelines for International Working Dog Trials and International Tracking Dog Trials of the F.C.I.

This document is a translation of various rules for the conduct of working dog examinations as used and approved by the FCI. These rules have been adopted for use by the Australian United Sportdog Clubs with certain amendments and variances. This document and any approved amendments shall be the official rulebook for the conduct of all working dog evaluation events sanctioned by the Australian United Sportdog Clubs. Unauthorized duplication is strictly forbidden. Copies of this publication can be obtained by contacting the AUSC Administrator of Records at Australian United Sportdog Clubs, 134 Kennington Park Dr, Endeavour Hills Vic 3802

AUSC variances from the following rules:

The Australian United Sportdog Clubs has requested and received variances from certain of the following international rules. The Board of Directors of AUSC has also adopted variances of its own accord. The following variances to the FCI rules are in effect for all AUSC trials.

1. The waiting period between trials has been reduced from two to one week.
2. The limit on the number of dogs to be judged by one judge in one day in a Dogsport trial has been increased from 10 to 12 dogs.
3. The minimum number of dogs for an official trial is four entries. Dogs must be present at the trial.
4. Completion of the BH is not required for dogs entering the AD.
5. All dogs entered in an AUSC sanctioned trial must pass a test of impartiality.
6. Certain rules pertaining to foreign dogs are irrelevant
7. Times for FH tracks laid have been adapted for Australian conditions

IPO rules written upon request of the FCI Commission for Utility Dogs by

Louis Quadroni (Switzerland),

Ferdinand Ritter (Czech Republic)

Hans Ruedenauer (Germany),

J.Visser (Holland),

Marcel Leclerc, Rudy Cattrysse, Fons van den Bosch (Belgium),

Jacques Wildanger (Luxembourg),

Eberhard Strasser (Austria)

The present RIC was adopted by the General Committee in Rome in November 2002

(Effective from January 1st 2003)

Revised and Effective in Australia from January 2004

Table of Contents

1. GENERAL ABBREVIATIONS	3
2. GENERAL PARTS	3
2.1 Validity	3
2.2 General information	3
2.3 Trial season	4
2.4 Trial organization/trial chairperson.....	4
2.5 Trial judges	4
2.6 Trial participants.....	5
2.7 Trial requirements	5
2.8 Temperament test.....	6
2.9 Scoring system	7
2.10 Disqualification.....	7
2.11 Evaluation	8
2.12 Scorebooks	8
2.13 Liability	8
2.14 Vaccinations.....	8
2.15 Trial supervision.....	8
2.16 Helper regulations.....	8
2.17 "tsb" evaluation	12
2.18 Special regulations.....	12
2.19 World championship	13
3. INTERNATIONAL TRIAL RULES IPO 1	13
3.1 IPO 1 (Phase A).....	13
3.2 IPO 1 (Phase B).....	15
3.3 IPO 1 (Phase C).....	20
4. INTERNATIONAL TRIAL RULES IPO 2	25
4.1 IPO 2 (Phase A).....	25
4.2 IPO 2 (Phase B).....	26
4.3 IPO 2 (Phase C).....	32
5. INTERNATIONAL TRIAL RULES IPO 3	38
5.1 IPO 3 (Phase A).....	38
5.2 IPO 3 (Phase B).....	40
5.3 IPO 3 (Phase C).....	46
6. TRACKING DOG EXAMINATION IPO – FH.....	52
6.1 General regulations.....	53
7. EQUIPMENT.....	54

1. GENERAL ABBREVIATIONS

FCI	International Working Dog Federation
IPO	International Trial Rules
LAO / AUSC	National Organization (Australian United Sportdog Clubs)
AKZ	Training Degree
PR	Trial Judge
PL.....	Trial Chairperson
HL.....	Helper
HF	Handler
FL.....	Tracklayer
HZ	Verbal Command

Note:

The verbal commands contained in this text, must be replaced with the verbal commands used by each National Organization, when translating the rulebook.

As soon as these rules become effective, all previous rules become invalid. If this is a translation, the original German text is binding when in doubt.

2. GENERAL PARTS

(2.1) Validity

These guidelines were drawn up by the FCI Working Dog Committee and were approved and voted on by the FCI on November 2002, in Rome.

These guidelines will become effective on 1 st January 2003 and will replace all previous regulations.

These guidelines were drawn up and discussed by the committee in German. In case of doubt, especially when translating into other languages, the original German text is binding.

These guidelines apply to all countries that are members of the FCI. All trials conducted under international trial rules (trials and tournaments) must comply with these rules.

(2.2) General Information

Trials and tournaments should serve two purposes. The first purpose is to determine a dog's suitability for a particular use by obtaining a title. The other purpose is to help to maintain or increase the health and working ability, as far as working dog characteristics are concerned, from generation to generation within the breeding program. They also help to maintain and increase health and fitness. A working title is also considered proof of a dog's breed worthiness.

FCI suggest that the National Organization (LAO/AUSC) promote the IPO. International events should be conducted under IPO Rules. All trials and tournaments are subject to sports related principles regarding the hosting of events and regarding the conduct of the participants. The regulations stated in these guidelines are binding for all persons involved. All competitors have to comply with the same performance requirements. The events are open to the public. The membership must be informed publicly of the location of the event and the time the event starts.

Trials and tournaments must comply with the complete examination levels or separate complete parts of a particular examination level. In any case, successfully completed entire examination level at an event reflects a valid training degree. The training degrees must be recognized by all countries that are members of the FCI.

(2.3) Trial Season

IPO 1–3 trials as well as IPO-FH trials can be held throughout the entire year if weather permits and health and safety of people and animals are not put at risk. Otherwise, the event cannot be held. This decision is made by the Trial Judge. The National Organization is entitled to make restrictions regarding the trial season for their area of authority.

(2.4) Trial Organization/Trial Chairperson

The trial chairperson is responsible to organize the event. The trial chairperson handles or supervises all tasks necessary to prepare and conduct a trial. He/she insures the correct course of events and must be at the judge's disposal throughout the entire event.

Therefore, the Trial Chairperson is not allowed to show a dog or take on other duties. The Trial Chairperson is responsible for:

- Obtaining all necessary event authorizations.
- Finding suitable (in accordance with regulations) tracking fields for all trial levels.
- Making arrangements with the owners of the tracking fields and persons who may have acquired hunting rights for this property.
- Getting experienced volunteers for example helpers for the protection phase, tracklayers, people for the group, etc.
- Securing the trial date.
- Providing all necessary trial equipment (in accordance with regulations) and proper protective clothing for the helpers.
- Providing forms, such as judge's books and scoresheets for all trial levels.
- Making scorebooks, registration papers, proof of vaccination and if necessary proof of liability insurance available.

The chairperson must inform the judge three days prior to the event of the location of the trial, the time the trial starts, directions to the trial site, type of examinations and number of dogs. If the trial chairperson fails to provide the judge with this information the judge has the right to withdraw from his/her appointment.

The event authorization form must be presented to the judge prior to the start of the trial.

(2.5) Trial Judges

The officers of the hosting club are responsible for inviting a judge who is authorized to conduct IPO trials, or the National Organization can assign a judge. For World Championships the judges are assigned by the FCI Working Dog Committee. The hosting club determines how many judges are invited. However, one judge may judge a maximum of 30 individual phases per day.

IPO – FH, IPO 1, IPO 2, IPO 3 equivalent to three phases each.

For major events scheduled by the National Organization, the National Organization can establish special regulations.

The judge is not permitted to evaluate dogs that are owned by him or that he has in his possession. The judge is not permitted to evaluate dogs that are owned or in the possession of a person living in the same household with him. He is not permitted to evaluate dogs that are shown by a person living in the same household. In the event that a judge is appointed by the National Organization or the Working Dog Committee of the FCI this rule does not apply.

The judge is not permitted to influence or distract a dog's performance through his behavior. The judge is responsible for the compliance and correct application of the valid trial regulations. The judge is entitled to terminate a trial if the trial is not conducted in compliance with the trial regulations and his instructions are ignored. In such a case the judge must submit a report to the National Organization.

A judge's decision is final and incontestable. Any form of criticism regarding the evaluation can lead to dismissal from the site and can eventually be followed by disciplinary measures.

In justified cases, regarding a violation of the trial regulations on the judge's part and not a judge's decision, a complaint can be filed within eight days.

The complaint is submitted in writing, signed by the plaintive and at least two witnesses, via the trial chairperson to the hosting club respectively the National Organization.

The acceptance of a complaint does not automatically lead to a revision of the judge's evaluation. A decision is made by the corresponding committee of the National Organization. The National Organization can pass the complaint on to the Working Dog Committee who will make the final decision.

(2.6) Trial Participants

The trial participant must meet the entry deadline for the event. With the submission of the entry form the participant agrees to pay the entry fee. In the event that the participant cannot participate in the trial for whatever reason he/she must immediately contact the trial chairperson. The trial participant must comply with any veterinary and animal protection regulations that are in effect for that region. The participant must follow the instructions of the judge as well as those of the trial chairperson. The handler must show the dog in a sporty and faultless manner. A handler must show his dog in all sections of the trial, regardless of the outcome in any one section. The trial ends with the announcement of the final scores (closing ceremony) and handing-out of the scorebooks.

The judge has the right to terminate a dog's trial performance, even against the wishes of the handler, if the dog is injured or otherwise incapacitated. If a handler pulls a dog from a trial the scorebook will be marked "insufficient - dog was pulled". If a dog is pulled from the trial on grounds of an obvious injury or a letter from a veterinarian is presented, certifying the dog's illness, the scorebook will be marked "pulled due to illness". The judge has the right to disqualify a handler on grounds of poor sportsmanship, carrying of motivational objects, violations against the trial regulations or animal protection rights or other ill-natured actions.

An entry in the scorebook must be made in any case, giving the reason for premature dismissal from the trial. In case of disqualification, all awarded points will be taken away.

The handler must carry a leash throughout the entire trial. This includes that the dog must wear a simple, single-row, loose-fitting chain collar in the neutral position (dead ring) at all times. Any other collars or additional collars (such as leather or tick-collars, etc.) are not permitted during the trial. The leash can be carried so it is invisible for the dog or the handler can put the leash over his/her shoulder from top left to bottom right.

Verbal commands are brief orders given in a normal voice, consisting of one single word. The commands can be given in any language. The same command must be used for the same task at all times.

If several participants are entered at the same trial level, starting positions are to be determined through a draw.

(2.7) Trial Requirements

On the day of the trial the dog must have reached the required age. No exceptions are allowed.

- > IPO 118 months
- > IPO 219 months
- > IPO 320 months
- > IPO–FH20 months

Only registered dogs from recognized AUSC working dog breeds are allowed to participate.

A handler is allowed to show in one trial per day. A handler is allowed to show no more than two dogs per trial. Dogs are only allowed to be exhibited in one trial per day. The minimum number of participants for a trial is four.

Each degree level can be repeated as many times as desired. The examination levels are to be completed in sequence (Level 1-2-3). A dog may only be shown at the next higher level upon passing the previous level. The age requirement must be taken into consideration. A dog must always be shown in the highest degree it has earned. An exception can be made in trials that are not connected with a qualification or formation.

Bitches in season may participate in all events. However, they must be kept apart from the rest of the participants. They will be shown according to schedule in Part A of the trial. In all other phases they will be placed at the end of the starting order. They will be shown at the end of the trial. Pregnant and nursing females are excluded from the trial.

Sick and contagious animals are excluded from all events.

(2.8) Temperament Test

Before any trial starts, prior to the first examination phase, the dogs must undergo an impartiality test (temperament test). Part of the temperament test is the identity-inspection (examination and verification of the tattoo-number, microchip, etc.).

Dogs that do not pass the temperament test are excluded from further participation in the trial and must be disqualified. Owners of dogs that are micro-chipped, are responsible for providing the necessary equipment for the identity check.

The judge will continue to evaluate the temperament throughout the entire trial. The judge is obligated to immediately disqualify a dog from the trial if that dog shows a faulty temperament. An entry must be made in the scorebook, explaining the temperament fault. Dogs that were disqualified due to a temperament fault must be reported in writing to the National Organization.

(2.8.1) Conducting of the Temperament Test

1. The temperament test must be performed under normal environmental conditions in a neutral location for the dog.
2. Each dog will be presented to the judge separately.
3. The dog is presented to the judge on a regular leash. The leash must be held loosely.
4. The judge must avoid any type of provocation. The judge is not allowed to touch the dog.

(2.8.2) Evaluation:

- (a) Positive response of the dog: The dog shows itself for example neutral, self-confident, sure, attentive, energetic, impartial
- (b) Still acceptable borderline cases: The dog is for example somewhat unstable, slightly nervous, slightly insecure. Such dogs can still pass the temperament test but must be kept under close observation throughout the entire trial.
- (c) Negative response of the dog or temperament fault: The dog is for example shy, insecure, nervous, gun-sensitive, out of control, bites, is aggressive (disqualification).

(2.9) Scoring System

A performance is evaluated in points and ratings (qualification). The ratings (qualification) and corresponding points must reflect the quality of the performance.

Point table:

maximum points	excellent	very good	good	satisfactory	insufficient
5 points	5	4.5	4.0	3.5	3.0-0
10 points	10	9.5-9.0	8.5-8.0	7.5-7.0	6.5-0
15 points	15.0-14.5	14.0-13.5	13.0-12.0	11.5-10.5	10.0-0
20 points	20.0-19.5	19.0-18.0	17.5-16.0	15.5-14.0	13.5-0
30 points	30.0-29.0	28.5-27.0	26.5-24.0	23.5-21.0	20.5-0
35 points	35.0-33.0	32.5-31.5	30.5-28.0	27.5-24.5	24.0-0
70 points	70.0-66.5	66.0-63.0	62.5-56.0	55.5-49.0	48.5-0
80 points	80.0-76.0	75.5-72.0	71.5-64.0	63.5-56.0	55.5-0
100 points	100.0-96.0	95.5-90.0	89.5-80.0	79.5-70.0	69.5-0

Percentages

Rating	Awarded percentage	Deduction
Excellent	= Deduction	or up to minus 4%
Very good	= 95 to 90%	or minus 5 to 10%
Good	= 89 to 80%	or minus 11 to 20%
Satisfactory	= 79 to 70%	or minus 21 to 30%
Insufficient	= below 70%	or minus 31 to 100%

Only whole points shall be given in the overall rating of each complete phase. Partial points may be given for individual exercises. When adding the points upon completion of each phase and the result does not consist of a whole number the points awarded may be rounded up or down, depending on the overall impression.

In case of a tie, the highest score in Phase C prevails. Should there still be a tie the points in Phase B shall prevail. Scores that coincide in all three phases shall be listed as an equal placing.

(2.10) Disqualification

If a dog leaves the handler or the field during the examination and does not return upon receiving three commands, the dog will be disqualified.

All points given up to the time of disqualification will be taken away. No ratings (qualifications) or points will be entered in the scorebook.

(2.11) Evaluation

A degree can only be awarded if a dog achieves at least 70% of the total points in each phase of a trial.

maximum points	excellent	very good	good	satisfactory	insufficient
100 points	100 - 96	95 - 90	89 - 80	79 - 70	69 - 0
300 points	300 - 286	285 - 270	269 - 240	239 - 210	209 - 0
200points (FH)	200 - 192	191 - 180	179- 160	159 - 140	139 - 0

(2.12) Scorebooks

Each participating dog must have a scorebook. The scorebook is issued according to the regulations of the handler's corresponding organization. Only one scorebook may be issued per dog. The organization issuing the scorebook is to be held responsible for this. The trial results must be entered in the scorebook under any circumstances. The judge and, if there is a provision made in the scorebook, the trail chairperson must check the entry and verify the entry with his/her signature.

(2.13) Liability

The owner of a dog is liable for any personal injury or material damage caused by his/her dog. The host club must have adequate public liability insurance. In case of an accident, the handler is liable for himself/herself and his/her dog throughout the event. The handler follows the instructions, given by the judge and the organizer, on his/her own free will and executes the instructions on his/her own risk.

(2.14) Vaccinations

On request of the judge or the trial secretary the handler must provide proof of proper vaccination (vaccination certificate).

(2.15) Trial Supervision

The AUSC Board of Management is entitled to supervise. The Board of Management can assign a knowledgeable person (i.e. the Chief Judge) to oversee an event to make certain the event is conducted in accordance with the regulations stated in the guidelines.

(2.16) Helper Regulations

(2.16.1) Requirements for the employment as helper in Phase "C":

1. The guidelines and regulations of the trial regulations regarding helper work must be followed.
2. The helper in Phase "C" is the assistant of the judge on the day of the trial.
3. For his personal safety as well as liability reasons, the helper must wear protective clothing (protective pants, protective jacket, sleeve, cup and if necessary gloves) when doing helper work during training, trials and competitions.
4. The shoes of the helper must be suitable for different weather/ground conditions. The shoes must provide the helper secure stance and good traction.
5. Before Phase "C" starts, the helper receives instructions from the judge. The helper must perform the helper work in accordance to the judge's instructions.

6. The helper must follow the handler's instructions during the disarming/search of the helper phase in accordance to the trial regulations. The helper must give the handler the opportunity to put the dog in a basic position before the side/back transport begins.
7. In club trials, it is allowed to work with one helper. If there are more than five dogs entered at an examination level, it is mandatory to employ two helpers. At trials at a national level, such as championships, qualification trials, etc. a minimum of two helpers must be used. In all these events, it is permitted to use a helper who lives in the same household as one of the handlers.

(2.16.2) Regulations concerning the conduct of trial helpers:

Part 1 In General:

During a trial, the judge is supposed to evaluate the training level and if possible the quality of a dog (for example instinctive behaviour, ability to cope with stress, self-confidence and obedience). The judge can objectively evaluate what he/she visually and acoustically observes during the course of the trial.

This factor and the aspect of maintaining fair trial conditions throughout the trial (which means offering the same conditions for all participants, if possible) make it essential that the helper work gives the judge a clear picture of a dog's performance.

Therefore, it cannot be left up to the helper how Phase "C" is structured. Furthermore, the helper has to follow certain rules. During the trial, the judge has to check the most important evaluation criteria concerning the individual elements of the exercises during Phase "C" of the trial.

These elements are for example the ability to cope with stress, self-confidence, instinctive behaviour, obedience. Furthermore, he must evaluate the quality of the grip of the dogs that are shown. Therefore, in order for the judge to evaluate the quality of the grip, the helper must give the dog a chance to get a good grip on the sleeve. Or, in order to evaluate the ability to cope with stress, it is necessary that the helper inflicts pressure on the dog through corresponding action. Therefore, it is desirable that the helpers perform the helper work in the most uniform manner possible, so that these elements can be evaluated.

Part 2 "Hold and bark" (Examination Level 1 - 3):

After the hold and bark exercise, the helper is called out of the blind by the handler. The helper steps out of the blind at a normal pace and takes position in a spot designated by the judge (marked escape position). The position assumed by the helper must allow the handler to put his/her dog in a down position to the side of the helper, in a spot designated by the judge, at a distance of about 5 paces from the helper, so that the dog can assume the down position on the side of the helper that is protected by the sleeve. It must be apparent to the handler in which direction the helper is going to move for the escape bite. Upon a signal from the judge, the helper makes a sudden attempt to escape at a fast pace and in a straight line, without displaying exaggerated or out of control movements. The protective sleeve is not to be moved around in addition to any normal movement to offer the dog an optimal bite. The helper may under no circumstances turn towards the dog during the escape. The helper may have the dog in his/her field of vision. The helper must refrain from pulling the sleeve away. As soon as the dog has a grip on the sleeve, the helper continues to run in a straight line while pulling the sleeve, while in motion, close to the body.

The judge determines how far the helper moves away for the escape. The helper stops the escape upon receiving a signal from the judge. An adequately energetic performance of the helper during the escape offers the judge an ideal opportunity

for an evaluation. Any type of help offered by the helper, for example excessive offering of the sleeve before the dog engages, verbal agitation or hitting the soft

stick against the pant leg of the protective suit before or during the escape, holding the sleeve without the necessary tension after the dog engages, slowing down as well as stopping the escape independently etc. is prohibited.

Stopping the exercise, see No. 8 (applies to all exercises)

Part 3 “Defense of the dog during guarding phase” (Examination Level 1 - 3):

After the guarding phase, upon a signal from the judge, the helper makes an attack on the dog. The soft stick is to be utilized by making threatening motions with it above the protective sleeve, without hitting the dog. At the same time, the helper is attacking the dog frontally by driving the dog forward with corresponding resistance, without additional movement of the sleeve. The sleeve is to be held close to the body. Once the dog has a grip on the sleeve, the helper places the dog, out of motion, to the side and the pressure phase begins in a straight direction. The helper must drive all dogs in the same direction. Therefore, the judge must position himself/herself in such a manner that it is possible to observe and evaluate how the dog acts while attacking, during the pressure phase, evaluate the grip, the release and the guarding phase. Driving the dog towards the handler is not permitted.

The hits with the soft stick are to be placed on the dog's shoulders and in the area of the withers. The intensity of the stick hits has to be the same for all dogs. The first hit is applied after 4-5 paces, the second hit after 4-5 more paces during the pressure phase. After the second stick hit additional pressure, without stick hits, is to be demonstrated. The judge determines the duration of the pressure phase. The helper stops the pressure phase, on a signal from the judge. An adequately energetic performance of the helper during the attack offers the judge an ideal opportunity for an evaluation. Any type of help offered by the helper, for example offering of the sleeve before the dog engages, verbal agitation or hitting the soft stick against the pant leg of the protective suit before the attack starts, holding the sleeve without the necessary tension after the dog engages and during the pressure phase, inconsistent intensity during the pressure phase and of the stick hits, stopping the attack independently if the dog shows an insufficient ability to cope with pressure etc. is prohibited.

Stopping the exercise see No. 8 (applies to all exercises)

Part 4 “Back-transport” (Examination Level 2+3):

The helper demonstrates a back-transport over a distance of about 30 paces, at a normal pace, upon receiving an order from the handler. The judge determines the course of the transport. The helper is not allowed to make any sudden moves during the back-transport. The soft stick and the sleeve are to be carried in such a manner that they do not present an additional stimulation for the dog. The soft stick in particular is to be carried out of the dog's sight. The helper is to move at the same pace for all dogs.

Part 5 “Attack on the dog out of the back-transport” (Examination Level 2+3):

The attack out of the back-transport is performed out of motion, upon a signal from the judge. The helper performs the attack by making a dynamic left or right turn and running energetically towards the dog. The soft stick is utilized by making threatening motions above the sleeve. The protective sleeve is to be carried in front of the helper, close to the body. Any additional movement of the sleeve is to be avoided. Once the dog has a grip on the sleeve, the helper places the dog, out of motion, to the side and the pressure phase begins in a straight direction. The helper must drive all dogs in the same direction. Therefore, the judge must position himself/herself in such a manner that it is possible to observe and evaluate how the dog acts while attacking, during the pressure phase, evaluate the grip, the release and the guarding phase. Driving the dog towards the handler is not permitted.

The judge determines the duration of the pressure phase. On a signal from the judge, the helper stops the pressure phase. An adequately energetic performance of the helper during the attack offers the judge an ideal opportunity for an evaluation. Any type of help offered by the helper, for example the helper swerves extremely to one side before the dog engages, offering of the sleeve before the dog engages, verbal agitation or hitting the soft stick against the pant leg of the protective suit as the attack starts, holding the sleeve without the necessary tension after the dog engages and during the pressure phase, inconsistent intensity during the pressure phase, stopping the attack independently if the dog shows an insufficient ability to cope with pressure etc. is prohibited.

Stopping of the exercise see No. 8 (applies to all exercises)

Part 6 “Attack on the dog out of motion” (Examination level 2+3):

On a signal from the judge, the helper leaves the assigned blind and moves to the centreline at a normal walking pace (Examination Level 1) / at a running pace (Examination Level 2 + 3). The handler orders the helper verbally to stop.

The helper ignores the instruction – and

- from a walking pace goes directly over to a running pace and performs a frontal attack on the handler and the dog while yelling and making threatening motions with the soft stick (Examination Level 1).
- without interrupting the running pace, the helper performs a frontal attack on the handler and the dog while yelling and making threatening motions with the soft stick (Examination Level 2 + 3).

The dog must be caught with an elastic sleeve position, without the helper coming to halt. When catching the dog, the handler must make a turn with his/her body – if necessary, to compensate for the dog’s momentum. Under no circumstances may the helper run around the dog. Once the dog has a grip on the sleeve, the helper places the dog, out of motion, to the side and the pressure phase begins in a straight direction. It must be prevented under any circumstances to overrun the dog. The helper must drive all dogs in the same direction. Therefore, the judge must position himself/herself in such a manner that it is possible to observe and evaluate how the dog acts while attacking, during the pressure phase, evaluate the grip, the release and the guarding phase. Driving the dog towards the handler is not permitted.

The judge determines the duration of the pressure phase. On a signal from the judge, the helper stops the pressure phase. An adequately energetic performance of the helper during the attack offers the judge an ideal opportunity for an evaluation. Any type of help offered by the helper, for example slowing down while attacking, catching the dog while standing still, the helper swerves extremely to one side before the dog engages, running around the dog, offering of the sleeve before the dog engages, holding the sleeve without the necessary tension after the dog engages and during the pressure phase, inconsistent intensity during the pressure phase, stopping the attack independently if the dog shows an insufficient ability to cope with pressure etc. is prohibited.

Stopping of the exercise see No. 8 (applies to all exercises)

Part 7 “Stopping the exercise” (applies to all exercises):

The stopping of all defense exercises must be conducted in such a manner that the judge can observe the grip, the out and the guarding phase of the dog (do not stop the exercise with the back turned towards the judge, maintain eye contact with the judge). Upon stopping the defense exercise, the helper must reduce the resistance against the dog. The helper is to stop the stimulation through movement without noticeably relaxing the arm with the sleeve. The protective sleeve is not to be carried high but remains in the same position it was in during the previous exercise.

The soft stick is to be held on the side of the body pointing downward, invisible for the dog. The helper is not allowed to provide any help for the dog to release. After the dog releases, the helper maintains eye contact with the dog. Additional stimulation as well as help of any kind is not permitted.

If the dog circles the helper during the holding phase, in order to keep an eye on the dog, the helper is allowed to turn with the dog, slowly and without any sudden movements.

Part 8 “Insecurities and failure of the dog”:

The helper has to continue to pressure a dog that does not engage or comes off the sleeve during a pressure phase, until the judge terminates the exercise.

The helper is under no circumstances allowed to provide any kind of help or stop the exercise independently. Dogs that does not release, may not be influenced by the helper through body posture or movement of the soft stick to release. The helper is not allowed to make dogs that have a tendency to leave the helper during the holding phase, stay with the helper by stimulating the dog. In all the exercises or parts of the exercises, the helper must present himself/herself active or neutral in accordance with the trial regulations. If a dog bumps or grips the helper during the holding phase, the helper must avoid making defensive motions.

(2.17) “Tsb” Evaluation (applies to all examination levels):

The “TSB”-Evaluation should serve the purpose of describing a dog’s character traits if the dog should be used for breeding purposes. The “TSB”-Evaluation does neither influence the trial result nor does it influence a formation. A dog must complete at least one protection exercise to receive a “TSB”-Evaluation.

The ratings pronounced (a), present (vh) and not sufficient (ng) describe the following characteristics:

- Triebveranlagung = instinctive behavior,
- Selbstsicherheit = self-confidence,
- Belastbarkeit = ability to cope with stress.

(2.17.1) TSB “Pronounced” – (a):

Is given to a dog that shows strong willingness to work, clear instinctive behavior, determination in its performance, presents itself in a self-confident manner, pays undivided attention and is capable to cope with a severe amount of stress.

(2.17.2) TSB “Present” – (vh):

Is given to a dog that has limitations concerning its willingness to work, instinctive behavior, self-confidence, attentiveness and ability to cope with stress.

(2.17.3) TSB “Not sufficient” – (ng):

Is given to a dog with insufficient willingness to work, insufficient instinctive behavior, missing self-confidence and insufficient ability to cope with stress.

(2.18) Special Regulations

The National Organization is entitled to expand (modify) the general FCI regulations for Australian conditions. For example rules concerning permits, veterinary requirements, animal protection decrees or sanitary regulations are allowed to be adjusted to a country’s differences in legislation.

Handlers may give verbal commands in their own language.

(2.19) World Championship

The rules and regulations stated in the “Pflichtenhefte” (Obligatory Set of Specifications) are in effect for the FCI World Championship. The Commission for Utility Dogs is in charge of publishing and revising the “Pflichtenhefte” (Obligatory Set of Specifications).

3. INTERNATIONAL TRIAL RULES IPO 1

is divided into:

Phase A	100 points
Phase B	100 points
Phase C	100 points
Total:	300 points

(3.1) IPO 1 – Phase A

- The track is laid by the handler, minimum of 300 paces
- 3 legs, 2 corners (approximately 90 degrees), 2 articles that belong to the handler
- at least 20 minutes old, time to work-out the track 15 minutes

Staying on the track	80 points
Articles (10+10)	20 points
Total:	100 points

General Regulations:

The judge or the person in charge of the tracking determines the pattern of the track, whereas the layout of the tracking field must be taken into consideration. Varying patterns must be used for the tracks. It is not permitted that the articles and corners on each track are placed at the same distance from each other. The start is to be marked clearly with a signpost. The marker is to be placed in the ground directly to the left of the scent pad.

The judge will draw for starting positions.

The handler (= tracklayer) must show the tracking articles to the judge or the person in charge of the tracking prior to laying the track. Only well-scented articles (at least 30 minutes old and scented by the handler) may be used. The handler (= tracklayer) remains for a brief moment on the scent pad and then proceeds at a normal pace in the direction prescribed by the judge. The corners are likewise to be made at a normal pace. The first article is placed on the track after a minimum of 100 paces on the first or second leg. The second article is to be placed at the end of the last leg. The articles are to be laid on the track while the tracklayer is in motion. After placing the last article at the end of the last leg, the tracklayer must proceed to walk straight ahead for a few more paces. Different types of articles are to be used on the same track (materials: Leather, fabric, wood). The articles must have a size of about 10 cm in length, 2-3 cm in width and 0.5-1 cm in thickness. Their color may not stand out considerably from that of the terrain. The dog must remain out of sight while the track is laid.

While the dog is working out the track, the judge and any accompanying persons are not permitted in the area of the track where the dog/handler team has the right to track.

(3.1.1) Verbal command : “such”/ “seek”

The verbal command “such” is permitted at the start and after the first article.

(3.1.2) Description of the Exercise:

The handler is preparing the dog for tracking. The dog may track off lead or on a 10 m tracking line. While tracking, the 10 m tracking line may be placed across the back, on the side or between the front and/or hindquarters of the dog. The tracking line may be attached directly to the collar, dead ring, or to the ring on the tracking harness.

The following types of tracking harnesses are permitted: breast-harness or Boettger-harness without any additional straps.

When called, the handler will report to the judge with the dog in a basic position. The handler will advise the judge whether the dog will pick up or indicate the articles. Any forceful influence is to be avoided prior to tracking, at the start and during tracking.

On command of the judge, the dog is taken slowly and calmly to the starting point and is set onto the track. The dog is to take the scent at the start calmly and intensely, with a deep nose. The dog must then proceed to track with a deep nose, maintaining a steady pace. The handler follows his/her dog at a distance of 10 m at the end of the tracking line.

When tracking off lead a distance of 10 m must be maintained as well. A certain amount of slack in the line is permissible, as long as the handler keeps the tracking line in his/her hand. The dog must work out corners confidently. After working out a corner the dog must continue to track at his regular pace. As soon as the dog reaches an article, it must immediately pick-up or indicate the article in a convincing manner, without help from the handler. The dog is permitted to stand, sit or return to the handler when picking-up an article. Moving forward with the article or picking-up the article while lying down is faulty. Indicating of the article may be done standing, sitting or lying down. It is permitted to alternate. As soon as the dog has indicated or picked-up an article, the handler must lay down the tracking line and go to his/her dog. By raising the arm with the article in his/her hand, the handler shows that the dog has found the article. Then the handler picks-up the tracking line and continues to work out the track with his/her dog. Upon completion of the track, the handler must show the articles that were found to the judge.

(3.1.3) Evaluation:

The speed with which the track is worked out is not a factor in the scoring, as long as the track is worked out intensely, evenly and convincingly and the dog shows a positive tracking attitude. A dog's checking to convince itself of the layout of the track is not faulty, as long as the dog does not leave the track. Aimless wandering, a high nose, urination/defecation, circling at the corners, continuous encouragement, leash-guidance or verbal help on the track or at the articles, faulty pick-up/indication of the articles and indicating of a false object will cause point deductions. The tracking work is to be terminated if the handler leaves the track by more than one line-length.

If the dog goes to leave the track and the handler restrains him from doing so, the judge will instruct the handler to follow the dog. The tracking-work is to be terminated if the handler fails to follow the judge's instructions. If the track is not completed within 15 minutes from the time the dog was put on the track, the judge will terminate the tracking-work. The performance shown before the tracking-work was terminated will be evaluated.

If a dog shows both options, in other words, if the dog indicates and picks-up the articles, while working out the articles, this is faulty.

A rating is only given for articles that are indicated in the manner that was announced to the judge when the handler reported in. Faulty indication/pick-up of an article flows into the evaluation of the corresponding leg.

No points are given for articles that are not indicated/picked-up.

The distribution of points, for each individual leg, for maintaining the track has to reflect the length and the degree of difficulty. Each leg is evaluated in points and ratings. If the dog is not tracking (lingering in the same place and the dog is not tracking), the judge may terminate the tracking-work even though the dog is still positioned on the track.

(3.2) IPO 1 – Phase B

Exercise 1:	Free heeling	20 points
Exercise 2:	Sit in motion	10 points
Exercise 3:	Down with recall	10 points
Exercise 4:	Retrieve on the flat	10 points
Exercise 5:	Retrieve over hurdle	15 points
Exercise 6:	Retrieve over scaling wall	15 points
Exercise 7:	Send-out with down	10 points
Exercise 8:	Long down under distraction	10 points
Total		100 points

General Regulations:

The judge gives the signal to begin each exercise. Everything else such as about turns, halts, changes-of-pace etc. will be carried out without signals from the judge.

The verbal commands are described in the guidelines. Verbal commands are normally spoken, brief commands, consisting of one word. The commands may be given in any language. However, the same command is to be used for the same task at all times. If a dog does not perform the exercise or part of the exercise after receiving three commands, the exercise is to be terminated without a score. For the recall it is permissible to use the dog's name instead of the verbal command "hier/come". However, the name of the dog in conjunction with any verbal command is considered a double command.

In a basic position the dog is sitting closely and straight on the left hand side of the handler, whereas the dog's shoulder is level with the handler's knee. Each exercise begins and ends in a basic position. It is only permitted to assume a basic position once at the start of an exercise. Brief praising of the dog is only permitted after each exercise is completed and only in a basic position. Upon praising the dog, the handler can assume a new basic position. In any case, there must be a distinct pause (approximately 3 seconds) in between praising the dog and starting a new exercise.

An exercise is developed out of a basic position. The handler must show a minimum of 10 paces or a maximum of 15 paces before giving the verbal command for the execution of the exercise.

Between all fronts and finishes, as well as the part where the handler returns to the sitting, standing or lying dog, a distinct pause (approximately 3 seconds) is to be observed, before a new verbal command may be given. When the handler returns to the dog, he/she may do so by approaching the dog from the front or by going around behind the dog.

Correct free heeling is to be demonstrated at all times in between exercises. The dog has to accompany the handler when he/she picks-up the dumbbells. It is not permitted to play with or "pump-up" the dog while the handler retrieves the dumbbells.

The about turn is a left about turn. The dog may come around behind the handler or back-up from the front. However, it must be performed in the same manner throughout the trial.

The dog may perform the finish by going around behind the handler or by executing a flip finish from in front of the handler.

The nonflexible hurdle is 100 cm high and 150 cm wide. The scaling wall consists of two parts connected at the top. The two sides of the wall are 150 cm wide and 191 cm high. The wall is to be positioned on the ground in such a manner that the vertical height is 180 cm. Both sides of the scaling wall must be covered with a non-skid material. Three cleats (approximately 24/48 mm) shall be attached to the upper part. All dogs entered in a trial must jump over the same obstacles.

For the retrieve exercises only dumbbells are allowed (650 gm). The dumbbells provided by the organizer are to be used by all participants. It is not permitted to place the dumbbell in the dog's mouth prior to the exercise.

If a handler forgets to perform an exercise, the judge will instruct the handler to perform the missing exercise. No points are deducted for this.

(3.2.1) Heeling Off Leash – 20 points

- (a) Verbal command: "fuss" / "heel"

The handler is permitted to use the command only when starting from a basic position and when changing pace.

- (b) Description of the Exercise:

Before starting the exercise the handler will approach the judge with his/her free-heeling dog. The handler will report to the judge. The dog should sit at heel during the reporting process. Out of the basic position the dog is to follow the handler attentively, happily and in a straight manner, upon receiving the verbal command "fuss/heel" from the handler. The dog's shoulder blade must remain level with the handler's left knee. When the handler stops, the dog must sit quickly and straight without any influence from the handler. At the start of the exercise handler and dog must walk 50 paces straight forward, without stopping. After demonstrating the about turn and 10-15 more paces the handler must show a fast and slow pace (at least 10 paces each). The transition from fast pace to slow pace is to be performed without any transitional steps in between. The two different paces must be distinctly different in speed.

Then, at a normal pace, handler and dog must perform at least one right turn, one left turn and one about turn. A halt from a normal pace must be performed at least once. While the handler and the dog walk down the first straight leg, two shots are fired (calibre 6 mm), five seconds apart. The shots are fired at a distance of at least 15 paces from the dog. The dog must remain indifferent to the gunshots. On instruction by the judge, at the end of the exercise, the handler and the dog walk through a moving group consisting of at least four people. In the group, the handler must heel the dog around two persons, one to the left and one to the right and must halt at least once in the group. The judge is entitled to ask the handler to repeat the exercise. The handler and the dog leave the group and assume a basic position.

- (c) Evaluation:

Forging, heeling wide, lagging, slow or hesitant sits, additional commands, physical help from the handler, inattentiveness during heeling at all paces and all turns and /or an unhappy working attitude of the dog are to be evaluated accordingly.

(3.2.2) Sit In Motion – 10 points

- (a) One verbal command each: "fuss/heel", "sitz/sit"

- (b) Description of the Exercise:

From a basic position the handler goes straight forward with his/her free-heeling dog. After 10-15 paces, the handler gives the verbal command "sitz/sit" and the dog must sit quickly and straight without the handler stopping, altering his/her pace or looking back at the dog. The handler goes on another 30 paces, then stops and turns immediately to face his/her calmly sitting dog. At the judge's signal the handler returns to the dog and positions him/herself on the dog's right side.

- (c) Evaluation:
Faulty build-up, slow sitting down, restless and inattentive sitting are to be evaluated accordingly. 5 points will be deducted if the dog lies down or remains standing.

(3.2.3) Down With Recall – 10 points

- (a) One verbal command each: "fuss" / "heel", "platz" / "down", "hier" / "come", "fuss" / "heel"
- (b) Description of the Exercise:
From a basic position the handler moves straight forward with his/her free-heeling dog. After 10-15 paces, the handler gives the dog the verbal command "platz/down". The dog must lie down quickly and straight without the handler stopping, altering his/her pace or looking back at the dog.

The handler goes on another 30 paces, then stops and turns immediately to face his/her calmly lying dog. At the judge's signal the handler recalls the dog using the command "hier/come" or the dog's name. The dog must come in happily, quickly and directly and must sit closely and straight in front of the handler. On the verbal command "fuss/heel", the dog must quickly go to sit straight beside the handler, whereas the dog's shoulder blade is level with the handler's knee.
- (c) Evaluation:
Faulty build-up, slow downing, restlessness, slow recall or slowing down while returning to the handler, splay-legged stance of the handler, faulty sit in front of the handler and a faulty finish are to be evaluated accordingly. If the dog remains standing or sits after receiving the command 5 points will be deducted.

(3.2.4) Retrieve On Flat – 10 points

- (a) One verbal command each: "bring" / "fetch", "aus" / "out", "fuss" / "heel"
- (b) Description of the Exercise:
From a straight basic position the handler throws a dumbbell (weight: 650g) about 10 paces far. The verbal command "bring/fetch" is not to be given until the dumbbell is lying completely still. The dog sits calmly and free next to the handler. Upon receiving the verbal command "bring/fetch", the dog is to run quickly and directly to the dumbbell, pick it up immediately and return it to the handler quickly and directly. The dog is to sit closely and straight in front of the handler. The dog is to hold the dumbbell calmly in his mouth until the handler, after a pause of about three seconds, takes the dumbbell away by giving the command "aus/out". The handler must hold the dumbbell calmly in his/her right hand, with the right arm stretched-out alongside the right side of the body. On the verbal command "fuss/heel", the dog must quickly go into a basic position and sit straight on the handler's left side, whereas the dog's shoulder blade is level with the handler's knee. The handler is not permitted to change positions during the entire exercise.
- (c) Evaluation:
Faulty basic position, slow go-out, faulty pick-up, slow coming back, dropping of the dumbbell, playing with the dumbbell or mouthing, splay-legged stance of the handler, faulty sit in front of the handler and faulty finish are to be evaluated accordingly. Throwing the dumbbell too short as well as help from the handler, without changing his/her position, leads to point deduction.

If the handler leaves his/her position before the exercise is finished, the exercise will be rated "faulty". If the dog does not retrieve the dumbbell, the exercise will be evaluated with 0 points.

(3.2.5) Retrieve Over Hurdle (100 cm) – 15 points

(a) One verbal command each: “hopp” / “jump”, “bring” / “fetch”, “aus” / “out”, “fuss” / “heel”

(b) Description of the Exercise:

The handler assumes a basic position in front of the hurdle with his/her dog, at a distance of at least 5 paces from the hurdle. From the basic position the handler throws a dumbbell (650g) over the 100 cm high hurdle. The verbal command “bring/fetch” is not to be given until the dumbbell is lying completely still. The dog sits calmly and free next to the handler.

Upon receiving the verbal command “hopp/ jump” (the verbal command “bring/fetch” must be given while the dog is jumping over the hurdle), the dog is to jump over the hurdle, run quickly and directly to the dumbbell, pick it up immediately, turn around and jump over the hurdle and return the dumbbell to the handler quickly and directly. The dog is to sit closely and straight in front of the handler. The dog is to hold the dumbbell calmly in his mouth until the handler, after a pause of about three seconds, takes the dumbbell from the dog by giving the verbal command “aus/out”. The handler must hold the dumbbell calmly in his/her right hand, with the right arm stretched-out alongside the right side of the body.

On the verbal command “fuss/heel”, the dog must quickly go into a basic position and sit quickly and straight on the handlers left side, whereas the dog’s shoulder blade is level with the handler’s knee. The handler is not permitted to change positions during the entire exercise.

(c) Evaluation:

Faulty basic position, slow jump and go-out, faulty pick-up, slow return-jump, dropping of the dumbbell, playing with the dumbbell or mouthing, splay-legged stance of the handler, faulty sit in front of the handler and faulty finish are to be evaluated accordingly. For touching of the hurdle up to 1 point must be deducted per jump and for stepping on the hurdle up to 2 points must be deducted.

Going-out jump	Retrieve	Return-jump
5 points	5 points	5 points

A partial score for the exercise is only possible if at least two out of the three parts of the exercise (going- out jump - retrieve – return jump) were completed.

Both jumps perfect, retrieve without faults = 15 points

Both jumps refused, retrieve without faults = 10 points

Both jumps perfect, dumbbell not retrieved = 10 points

If the dumbbell that is thrown by the handler lands too far over to one side or is poorly visible for the dog, the handler may ask the judge for permission to re-throw the dumbbell, or the judge may suggest a re-throw. No point deduction will result from this. The dog must remain sitting while this is going on.

Any handler-help without changing his/her position, is to be evaluated accordingly. If the handler leaves his/her position before the exercise is finished, the exercise is rated “faulty”.

(3.2.6) Retrieve Over The Wall (180 cm) – 15 points

(a) One verbal command each: “hopp” / “jump”, “bring” / “fetch”, “aus” / “out”, “fuss” / “heel”

(b) Description of the Exercise:

The handler assumes a basic position in front of the scaling wall with his/her dog, at a distance of at least 5 paces from the wall. From the basic position the handler throws a dumbbell (650g) over the scaling wall.

The dog sits calmly and free next to the handler. Upon receiving the verbal command "hopp/jump" (the verbal command "bring/fetch" must be given while the dog is climbing over the wall) the dog must climb over the wall, run quickly and directly to the dumbbell, pick it up immediately, turn around and immediately climb back over the scaling wall and return the dumbbell quickly and directly.

The dog is to hold the dumbbell calmly in his mouth until the handler, after a pause of about three seconds, takes the dumbbell from the dog by giving the verbal command "aus/out". The handler must hold the dumbbell calmly in his/her right hand, with the right arm stretched-out alongside the right side of the body. On the verbal command "fuss/heel", the dog must quickly go into a basic position and sit straight on the handlers left side, whereas the dog's shoulder blade is level with the handler's knee. The handler is not permitted to change positions during the entire exercise.

(c) Evaluation:

Faulty basic position, slow jump and go-out, faulty pick-up, slow return-jump, dropping of the dumbbell, playing with the dumbbell or mouthing, splay-legged stance of the handler, faulty sit in front of the handler and faulty finish are to be evaluated accordingly. For touching of the hurdle up to 1 point must be deducted per jump and for stepping on the hurdle up to 2 points must be deducted.

Going-out jump	Retrieve	Return-jump
5 points	5 points	5 points

A partial score for the exercise is only possible if at least two out of the three parts of the exercise (going-out jump – retrieve – return jump) were completed.

Both jumps and retrieve without faults = 15 points

Both jumps refused, retrieve without fault = 10 points

Both jumps perfect, dumbbell not retrieved = 10 points

If the dumbbell that is thrown by the handler lands too far over to one side or is poorly visible for the dog, the handler may ask the judge for permission to re-throw the dumbbell, or the judge may suggest a re-throw. No point deductions will result from this. The dog must remain sitting during all this.

Any handler-help without changing his/her position, is to be evaluated accordingly. If the handler leaves his/her position before the exercise is finished, the exercise is rated "faulty".

(3.2.7) Send-Out With Down – 10 points

(a) One verbal command each: "voraus" / "go out", "platz" / "down", "sitz" / sit"

(b) Description of the Exercise:

From a basic position, the handler walks with his/her free-heeling dog in the direction he/she has been instructed to go by the judge. After 10-15 paces the handler gives the dog the verbal command "voraus/go-out". Simultaneously the handler lifts his/her arm (only once) and stops. The dog must go out purposefully, at a fast pace and in a straight line, at least 30 paces in the indicated direction. On the judge's signal, the handler gives the verbal command "platz/down". The dog must down immediately. The handler may keep his/her

arm raised until the dog lies down. On the judge's signal, the handler returns to his/her dog and locates him/herself on the dog's right side. After about three seconds the handler gives the dog the verbal command "sitz/sit" and the dog must sit-up quickly and straight into a basic position.

(c) Evaluation:

Faulty build-up, the handler is following the dog, dog is going-out too slowly, strong deviation to the side, too short of a distance, too early or hesitant lying down, restless lying down or standing-up/sitting-up prematurely when the handler picks-up the dog are to be evaluated accordingly.

(3.2.8) Long Down Under Distraction – 10 points

(a) One verbal command each: "platz" / "down", "sitz" / "sit"

(b) Description of the Exercise:

Before the beginning of another dog's obedience exercise in Phase B, the handler downs his/her dog with the verbal command "platz/down", out of a straight basic position, in a spot designated by the judge, without leaving the leash or any type of article with the dog. Then, the handler walks away without turning around, within the boundaries of the exercise grounds, about 30 paces, and remains there quietly standing in sight of the dog, with his/her back towards the dog. The dog must calmly remain in the down position without any influence from the handler, while the other dog is performing exercise 1-6. On the judge's signal, the handler returns to the dog and positions him/herself on the dog's right side. After a brief pause of about three seconds, the dog receives the command "sitz/sit". The dog is to sit-up quickly and straight into a basic position.

(c) Evaluation:

Restless behaviour of the handler or other hidden handler-help, restless lying down or premature standing-up/sitting-up when the handler returns, are to be evaluated accordingly. If the dog sits-up or is standing but remains in the designated area, partial points will be given. If the dog removes itself from the designated area by more than 3 meters before the other dog has completed exercise # 3, 0 points will be given for this exercise. If the dog leaves the designated area after exercise 3 is completed, partial points will be given. If the dog walks towards the handler when the handler returns to the dog, up to 3 points may be deducted.

(3.3) IPO 1 – Phase C

Exercise 1:	Search for the helper	5 points
Exercise 2:	Hold and bark	10 points
Exercise 3:	Prevention of an attempted escape of the helper	20 points
Exercise 4:	Defence of the dog during guarding phase	25 points
Exercise 5:	Attack on the dog out of motion	30 points
Total		100 points

General Regulations:

In a suitable location six blinds are to be set-up along the length of the field, in a staggered fashion, three on each side (see sketch). Necessary markings must be clearly visible for the handler, the judge and the helper.

The helper must be equipped with a protection suit, sleeve and soft-stick. The sleeve must be equipped with a bite-bar and the sleeve-cover must be made from burlap (jute) in a natural colour.

If it is necessary for the helper to keep a close eye on the dog during the guarding phase, the helper is not required to stand still, though he is not permitted to make any threatening or defensive movements. The helper must protect his body with the sleeve. It is up to the handler in which way he/she chooses to take the soft-stick away from the helper. (See also “General Information” page 9-12 – “Helper Regulations”)

It is possible to work with only one helper at all examination levels. If more than 5 dogs are entered at the same examination level a second helper is mandatory. All dogs within the same examination level must be worked by the same helper/helpers.

Dogs that are out of control, that, after a defense exercise, do not release or release only after the handler takes physical measures, that bite other parts of the helper’s body than the sleeve, must be disqualified. No TSB rating is given.

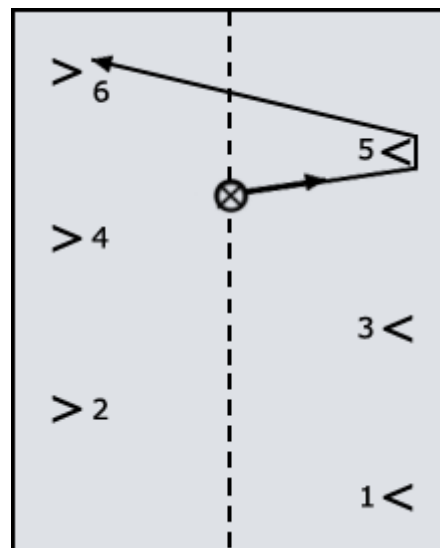

For dogs that fail during a defense exercise or get chased away, the protection phase is to be terminated. The dog does not receive a rating in the protection phase. However, the dog must receive a TSB rating.

The verbal command “aus/out” is permitted one time during all defense exercises. Evaluation for the “Out” see the table below.

Slow out	First additional command followed by immediate out	First additional command followed by slow out	Second additional command followed by immediate out	Second additional command followed by slow out	No out after Second additional command, respectively additional influence
0.5 - 3.0	3.0	3.5 - 6.0	6.0	6.5 - 9.0	Disqualification

(3.3.1) Search For The Helper – 5 points

- (a) One verbal command each: “revier” / “search or “voran” / “go-ahead”, “hier” / “come” (the verbal command “hier/come” may be given in conjunction with the dog’s name)
- (b) Description of the Exercise:

The helper is located in the last blind, out of the dog’s sight. The handler positions him/herself with his/her free-heeling dog between the fourth and fifth blind prior to starting the blind-search, so that two side-sweeps are possible. On the judge’s signal phase C begins.

After the handler gives the verbal command “revier/search” in conjunction with a visual command, which is executed with either the right or left arm and may be repeated, the dog must quickly leave the handler and approach the fifth blind. The dog must run around the blind closely and attentively. As soon as the dog has searched the fifth blind the handler gives the dog the verbal command “hier/come” (it is permissible to use the dog’s name in conjunction with the command) and sends the dog while he/she is in motion, by using the verbal command “revier/search”, into the helper-blind. The handler is moving at a normal pace down an imaginary middle line. The handler is not permitted to leave this imaginary line during the search for the helper. The dog must be in front of the handler at all times. When the dog reaches the helper-blind the handler is required to stand still. At this point no further verbal or visual commands are permitted.

(c) Evaluation:

Limitations concerning manageability, fast and purposeful approach of the blinds as well as close and attentive running around the blind are to be deducted accordingly.

(3.3.2) Hold & Bark – 10 points

(a) One verbal command each: “hier” / “come”, “fuss” / “heel”

(b) Description of the Exercise:

The dog must confront the helper actively and attentively and bark continuously. The dog is not permitted to jump on or grip the helper. After the dog has barked for approximately 20 seconds, the handler approaches the blind, upon receiving a signal from the judge and stops about 5 paces away from it. On the judge's signal the handler calls his/her dog out of the blind into a basic position.

(c) Evaluation:

Limitations regarding the continuous and demanding bark and forceful hold, not influenced by the judge or the approaching handler until the verbal command is given, are to be deducted accordingly. 5 points are given for continuous barking. For weak barking 2 points are deducted. If the dog does not bark but is guarding the helper actively, attentively and closely 5 points are deducted. Bothering of the helper, for example bumping, jumping up on the helper etc. leads to a deduction of up to 2 points. Up to 9 points may be deducted for heavy gripping. If the dog leaves the helper before the handler receives the signal from the judge to leave the middle line, the dog may be sent into the blind a second time. If the dog stays with the helper this time, the protection phase may be continued, though the hold and bark is to be rated “insufficient”. If the dog does not want to search the blind or leaves the helper again, phase C is to be terminated. If the dog returns to the handler when he/she approaches the blind to pick-up the dog, or the dog returns to the handler prior to receiving the verbal command to do so, partial points are given reflecting an “insufficient” rating.

(3.3.3) Prevention Of An Attempted Escape Of The Helper – 20 points

(a) One verbal command each: “fuss” / “heel”, “platz” / “down”, “aus” / “out”

(b) Description of the Exercise:

Upon a signal from the judge, the handler orders the helper to step out of the blind. The helper moves at a normal pace to the designated location for the escape. On a signal from the judge, the handler moves with his/her free-heeling dog to the designated location for the dog to down before the escape. The distance between dog and helper is 5 paces. The handler leaves his/her guarding dog in the down position and moves into the blind, maintaining visual contact with the dog, the judge and the helper. On the judge's signal the helper tries to escape. The dog must immediately and independently prevent the escape effectively, without hesitation and by means of an energetic and strong grip. The dog may only bite the helper's sleeve. On the judge's signal the helper stands still. When the helper stops moving the dog is to release immediately. The handler may give a verbal command “aus/out” on his/her own, within an appropriate time.

If the dog does not release after the first command, the handler may give up to two additional commands “aus/out”, upon receiving a signal from the judge. If the dog does not release after having received three commands (one permissible and two additional commands), the team is to be disqualified. The handler has to be stand calmly, without influencing the dog in any way, while giving the command “aus/out”. Upon releasing the helper, the dog must stay close to the helper and guard him attentively.

(c) Evaluation:

Limitations concerning important evaluation criteria are to be deducted accordingly. Fast and energetic response and pursuit in conjunction with a powerful engagement and effective prevention of the escape, full and calm grip until the release, attentive and close guarding of the helper. If the dog remains in the down position or has not prevented the escape by means of biting and holding after the helper has taken about 20 steps, the protection phase is to be terminated.

If the dog is slightly inattentive and/or bothers the helper slightly during the guarding phase the exercise will be marked down by one grade. If the dog is guarding the helper very inattentively and/or is bothering the helper very much, the exercise is marked down by two grades. If the dog is not guarding the helper but stays with him, the exercise is marked down by three grades. If the dog leaves the helper or if the handler gives a verbal command for the dog to stay on the helper, Phase C is to be terminated.

(3.3.4) Defense Of The Dog During Guarding Phase – 35 points

(a) One verbal command each: “aus” / “out”, “fuss” / “heel”

(b) Description of the Exercise:

After a guarding phase of about 5 seconds the helper makes an attack on the dog, on the judge's signal. Without any influence from the handler the dog must defend itself through energetic and powerful gripping. The dog may only bite the protective sleeve of the helper. As soon as the dog has a grip on the sleeve, the helper applies two stick-hits. Hits may only be applied to the shoulders and the area of the withers. Upon a signal from the judge the helper stands still. After the helper has stopped the attack and is standing still, the dog must out immediately. The handler may give a verbal command “aus/out” on his own at the appropriate time.

If the dog does not release after having received the first permissible command, the handler may give up to two additional commands “aus/out”, upon receiving a signal from the judge. If the dog does not release, upon receiving these commands (one permissible and two additional commands), the team is to be disqualified. The handler must stand still without influencing the dog in any other form, while giving the verbal command “aus/out”. After the dog releases, the dog must stay close to the helper and guard him attentively. Upon a signal from the judge the handler walks directly to his/her dog at a normal pace and with the verbal command “fuss/heel” he puts the dog in a basic position. The soft-stick is not taken from the helper.

(c) Evaluation:

Limitations concerning important evaluation criteria are to be deducted accordingly. Fast and strong engagement, full and calm grip until the release, attentive and close guarding of the helper.

If the dog is slightly inattentive and/or bothers the helper slightly during the guarding phase, the exercise will be marked down by one grade.

If the dog is guarding the helper very inattentively and/or is bothering the helper very much, the exercise is marked down by two grades. If the dog is not guarding the helper but stays with him, the exercise is marked down by three grades. If the dog comes towards the handler when he/she approaches, the exercise is rated “insufficient”. If the dog leaves the helper before the judge gives the signal to step-up or the handler gives a command for the dog to stay on the helper, the protection phase is terminated.

(3.3.5) Attack On Dog Out Of Motion – 30 points

(a) One verbal command each: “sitz” / “sit”, “voran”, or pack-ihn/go out, or defend”, “aus” / “out”, “fuss” / “heel”, “fuss” / “heel”

(b) Description of the Exercise:

The handler is sent with his/her dog to a marked spot on the centreline of the exercise ground, level with the first blind. The dog may be held by its collar but it is not permissible to stimulate the dog.

On a signal from the judge the helper, who is equipped with a soft-stick, steps out of the blind and walks at a normal pace towards the centreline. The helper disregards the handler's command to stop, he runs towards the handler and the dog (at a running pace), making a frontal attack while yelling and making strong threatening motions. As soon as the helper has reached a point about 30 to 40 paces away from the handler and his/her dog, the handler releases the dog upon receiving a signal from the judge with the verbal command "voran/ pack-ihn/go out/defend". The dog is to engage without hesitation and must prevent the attack by means of an energetic and strong grip. The dog may only grip the protective sleeve of the helper. The handler may not move from his/her position. On a signal from the judge, the helper stops the attack. After the helper has stopped the attack and is standing still, the dog must release immediately. The handler may give a verbal command "aus/out" on his/her own at the appropriate time.

If the dog does not release after having received the first permissible command, the handler may give up to two additional commands upon receiving a signal from the judge. If the dog does not release after having received these commands (one permissible and two additional commands), the team is to be disqualified. The handler must stand still without influencing the dog in any form, while giving the verbal command "aus/out". After the dog releases, the dog must stay close to the helper and guard him attentively. Upon a signal from the judge the handler walks directly to his/her dog at a normal pace and, with the verbal command "fuss/heel", puts the dog in a basic position. The soft-stick is taken from the handler.

This is followed by a side-transport of the helper to the judge over a distance of about 20 paces. A verbal command "fuss/heel" is allowed. The dog must walk on the helper's right side, so that the dog is in between the handler and the helper. The dog must watch the helper closely during the transport. The dog may neither bother, nor jump on nor grip the helper. The group stops in front of the judge. The handler presents the soft-stick to the judge and reports out. Prior to the critique and on the instruction of the judge, the dog is put on a leash.

(c) Evaluation:

Limitations concerning important evaluation criteria are to be deducted accordingly: Energetic defense with a powerful engagement, a full and calm grip until the release, attentive and close guarding of the helper.

If the dog is slightly inattentive and/or bothers the helper slightly during the guarding phase, the exercise will be marked down by one grade. If the dog is guarding the helper very inattentively and/or is bothering the helper very much, the exercise is marked down by two grades. If the dog is not guarding the helper but stays with him, the exercise is marked down by three grades. If the dog comes towards the handler when he/she approaches, the exercise is rated "insufficient".

If the dog leaves the helper before the judge gives the signal to step-up or the handler gives a command for the dog to stay on the helper, the protection phase is to be terminated.

4 INTERNATIONAL TRIAL RULES IPO 2

(4.1) IPO 2 – Phase A

- The track is laid by a stranger to the dog, minimum of 400 paces
- 3 legs, 2 corners (approximately 90 degrees), 2 articles
- at least 30 minutes old, time to work-out the track 15 minutes

Staying on the track	80 points
Articles (10+10)	20 points
Total:	100 points

General Regulations:

The judge or the person in charge of the tracking determines the pattern of the track, whereas the layout of the tracking field must be taken into consideration. Varying patterns must be used for the tracks. It is not permitted that the articles and corners on each track are placed in the same distance from each other. The start is to be marked clearly with a signpost. The marker is to be placed in the ground directly to the left of the scent pad.

After the tracks are laid, the starting positions of the participants are determined through a draw, in the presence of the judge.

The tracklayer must show the tracking articles to the judge or the person in charge of tracking, prior to laying the track. Only well-scented articles (at least 30 minutes old) may be used. The tracklayer remains for a brief moment on the scent pad and then proceeds at a normal pace in the direction prescribed by the judge. The corners are likewise to be made at a normal pace. The first article is placed on the track after a minimum of 100 paces on the first or second leg. The second article is to be placed at the end of the last leg. The articles are to be laid on the track while the tracklayer is in motion. After placing the last article at the end of the last leg, the tracklayer must proceed to walk straight ahead for a few more paces. Different types of articles are to be used on the same track (materials: Leather, fabric, wood). The size of the articles may not exceed 10 cm in length, 2-3 cm in width and 0.5-1 cm in thickness. Their colour may not stand out considerably from that of the terrain. All articles are to be marked with numbers. The numbers on the articles must coincide with the numbers on the signposts. Handler and dog must remain out of sight while the track is laid.

While the dog is working out the track, the judge, tracklayers and any accompanying persons are not permitted in the area of the track where the dog/handler team has the right to track.

(4.1.1) Verbal command : “such”/ “seek”

The verbal command “such/Seek” is permitted at the start and after the first article.

(4.1.2) Description of the Exercise:

The handler is preparing the dog for tracking. The dog may track free, off lead, or on a 10 m tracking line. While tracking the 10 m tracking line may be placed across the back, on the side or between the front and/or hindquarters of the dog.

The tracking line may be attached directly to the collar, dead ring, or to the ring on the tracking harness.

The following type of tracking harnesses are permitted: breast-harness or Boettger-harness without any additional straps. When called, the handler will report to the judge with the dog in a basic position. The handler will advise the judge whether the dog will pick-up or indicate the articles. Any forceful influence is to be avoided prior to tracking, at the start and during tracking.

On command of the judge, the dog is taken slowly and calmly to the starting point and is set onto the track. The dog is to take the scent at the start calmly and intensely with a deep nose. The dog must then proceed to track with a deep nose, maintaining a steady pace. The handler follows his/her dog in a distance of 10 m at the end of the tracking line. When tracking off lead, a distance of 10 m must be maintained as well. A certain amount of slack in the line is permissible, as long as the handler keeps the tracking line in his/her hand. The dog must work out corners confidently. After working out a corner, the dog must continue to track at his regular pace.

As soon as the dog reaches an article it must immediately pick-up or indicate the article in a convincing manner, without help from the handler. The dog is permitted to stand, sit or return to the handler when picking-up an article. Moving forward with the article or picking-up the article while lying down is faulty. Indicating of the article may be done standing, sitting or lying down. It is permitted to alternate. As soon as the dog has indicated an article, the handler puts down the tracking line and goes to his/her dog. By raising the arm with the article in his/her hand, the handler shows that the dog has found the article. Then the handler picks-up the tracking line and handler and dog continue to work out the track. Upon completion of the track, the handler must show the articles that were found to the judge.

(4.1.3) Evaluation:

The speed with which the track is worked out is not a factor in the scoring, as long as the track is worked out intensely, evenly and convincingly and the dog shows a positive tracking attitude. A dog's checking to convince itself of the layout of the track is not faulty, as long as the dog does not leave the track. Aimless wandering, a high nose, urination/defecation, circling at the corners, continuous encouragement, leash-help or verbal help on the track or at the articles, missing pick-up/indication of the articles and indicating a false object are faulty and will cause point deductions. The tracking work is to be terminated if the handler leaves the track by more than one line-length. If the dog goes to leave the track and the handler restrains him from doing so, the judge will instruct the handler to follow the dog.

The tracking work is to be terminated by the judge if the handler fails to follow the judge's instruction. If the track is not completed within 15 minutes from the time the dog was put on the track, the judge will terminate the tracking work. The performance shown before the tracking work was terminated will be evaluated. If a dog shows both options, in other words, if the dog indicates and picks-up the articles, while working out the articles, this is faulty. A rating is only given for articles that are indicated in the manner that was announced to the judge when the handler reported in. Faulty indication/pick-up of an article flows into the evaluation of the corresponding leg.

No points will be given for articles that were not indicated or picked-up.

The distribution of points for each individual leg, for maintaining the track, has to reflect the length and the degree of difficulty. Each leg is evaluated in points and ratings. If the dog is not tracking (lingering in the same place and the dog is not tracking), the judge may terminate the tracking work even though the dog is still positioned on the track.

(4.2) IPO 2 – Phase B

Exercise 1:	Free heeling	10 points
Exercise 2:	Sit in motion	10 points
Exercise 3:	Down with recall	10 points
Exercise 4:	Stand In motion (walking)	10 points
Exercise 5:	Retrieve on the flat	10 points
Exercise 6:	Retrieve over hurdle	15 points
Exercise 7:	Retrieve over scaling wall	15 points

Exercise 8:	Send-out with down	10 points
Exercise 9:	Long down under distraction	10 points
Total		100 points

General Regulations:

The judge gives the signal to begin each exercise. Everything else such as about turns, halts, change of pace etc. will be carried out without signals from the judge.

The verbal commands are described in the guidelines. Verbal commands are normally spoken, brief commands, consisting of one word. The commands may be given in any language. However, the same command is to be used for the same task at all times. If a dog does not perform the exercise or part of the exercise after receiving three commands, the exercise is to be terminated without a score. For the recall it is permissible to use the dog's name instead of the verbal command "hier/come". However, the name of the dog in conjunction with any verbal command is considered a double command.

In a basic position the dog is sitting closely and straight on the left hand side of the handler, whereas the dog's shoulder is level with the handler's knee. Each exercise begins and ends in a basic position. The basic position at the start of an exercise may only be assumed one time. Brief praising of the dog is only permitted after each exercise is completed and only in a basic position.

Upon praising the dog the handler can assume a new basic position. In any case, there must be a distinct pause (approximately 3 seconds) in between praising the dog and starting a new exercise.

An exercise is developed out of a basic position. The handler must show a minimum of 10 paces or a maximum of 15 paces before giving the verbal command for the execution of the exercise. Between all fronts and finishes as well as the part where the handler returns to the sitting, standing or lying dog, a distinct pause (approximately 3 seconds) is to be observed. When the handler returns to the dog, he/she may do so by approaching the dog from the front or by going around behind the dog.

Correct free heeling is to be demonstrated at all times in between exercises. The dog must accompany the handler when picking-up the dumbbells. It is not permitted to play or pump-up the dog while the handler retrieves the dumbbells.

The about turn is a left about turn. The dog may come around behind the handler or back-up from the front. However, it must be performed in the same manner throughout the trial. The dog may perform the finish by going around behind the handler or by executing a flip finish from in front of the handler.

The nonflexible hurdle is 100 cm high and 150 cm wide. The scaling wall consists of two parts connected at the top. The two sides of the wall are 150 cm wide and 191cm high. The wall is to be positioned on the ground in such a manner that the vertical height is 180cm.

Both sides of the scaling wall must be covered with a non-skid material. Three cleats (approximately 24/48 mm) shall be attached to the upper part. All dogs entered in a trial must jump over the same obstacles.

For the retrieve exercises only dumbbells are allowed. It is important to comply with the weight restrictions for the dumbbells (on flat ground -1000g – hurdle/scaling wall – 650g). The dumbbells provided by the organizer are to be used by all participants. It is not permitted to place the dumbbell in the dog's mouth prior to the exercise.

If a handler forgets to perform an exercise, the judge will instruct the handler to perform the missing exercise. No points are deducted for this.

(4.2.1) Heeling Off Leash – 10 points

- (a) Verbal command: "*fuss*" / "*heel*"

The handler is permitted to use the command only when starting from a basic position and when changing pace.

(b) Description of the Exercise:

Before starting the exercise the handler will approach the judge with his/her free-heeling dog. The handler will report to the judge. The dog should sit at heel during the reporting process. Out of a basic position the dog is to follow the handler attentively, happily and in a straight manner, upon receiving the command "fuss/heel from the handler.

The dog's shoulder blade must remain level with the handler's left knee. When the handler stops, the dog must sit down quickly and straight without any influence from the handler. At the start of the exercise the handler and the dog must walk forward 50 paces without stopping. After demonstrating the about turn and 10-15 more paces the handler must show a fast and slow pace (at least 10 paces each). The transition from fast pace to slow pace is to be performed without any transitional steps in between. The two different paces must be distinctly different in speed.

Then, at a normal pace, the handler and the dog must perform at least one right turn, one left turn and one about turn. A halt from a normal pace must be performed at least once. While the handler and the dog walk down the first straight leg, two shots are fired (calibre 6 mm), five seconds apart. The shots are fired at a distance of at least 15 paces from the dog. The dog must remain indifferent to the gunshots. On instruction by the judge, at the end of the exercise, handler and dog walk through a moving group, consisting of at least four people. In the group, the handler must heel the dog around two persons, one to the left and one to the right and must halt at least once in the group. The judge is entitled to ask the handler to repeat the exercise. The handler and the dog leave the group and assume a basic position.

(c) Evaluation:

Forging, heeling wide, lagging, slow or hesitant sits, additional commands, physical help from the handler, inattentiveness during heeling at all paces and all turns and /or an unhappy working attitude of the dog are to be evaluated accordingly.

(4.2.2) Sit In Motion – 10 points

(a) One verbal command each: "fuss/heel", "sitz/sit"

(b) Description of the Exercise:

From a basic position the handler goes straight forward with his/her free-heeling dog. After 10-15 paces, the handler gives the verbal command "sitz/sit" and the dog must sit down immediately and in direction of movement (straight) without the handler stopping, altering his/her pace or looking back at the dog. The handler goes on another 30 paces, then stops and turns immediately to face his/her calmly sitting dog. At the judge's signal the handler returns to the dog and positions him/herself on the dog's right side.

(c) Evaluation:

Faulty build-up, slow sitting down, restless and inattentive sitting are to be evaluated accordingly. 5 points will be deducted if the dog lies down or stands.

(4.2.3) Down With Recall – 10 points

(a) One verbal command each: "fuss" / "heel", "platz" / "down", "hier" / "come", "fuss" / "heel"

(b) Description of the Exercise:

From a basic position the handler moves straight forward with his/her free-heeling dog. After 10-15 paces, the handler gives the dog the verbal command "platz/down". The dog must lie down immediately and in direction of movement (straight) without the handler stopping, altering his/her pace or looking back at the dog. The handler goes on another 30 paces, then stops and turns

immediately to face his/her calmly lying dog. On the judge's signal, the handler recalls the dog, using the command "hier/come" or the dog's name. The dog must come in happily, quickly and directly and must sit closely and straight in front of the handler.

On the verbal command "fuss/heel", the dog must quickly go to sit straight beside the handler, whereas the dog's shoulder blade is to be level with the handler's knee.

(c) Evaluation:

Faulty build-up, slow downing, restlessness, slow recall or slowing down during recall, splay-legged stance of the handler, faulty sit in front of the handler and a faulty finish are to be evaluated accordingly. If the dog remains standing or sits after receiving the command

(4.2.4) Stand In Motion (Walk) – 10 points

(a) One verbal command each: "*fuss*" / "*heel*", "*steh*" / "*stand*", "*sitz*" / "*sit*"

(b) Description of the Exercise:

From a basic position, the handler moves straight forward with his/her free-heeling dog. After 10-15 paces, on the verbal command "steh/stand", the dog must stand immediately and in direction of movement (straight), without the handler breaking stride or looking back. After 30 more paces the handler stops and turns immediately around to face his/her calmly standing dog. On the judge's signal the handler returns directly to the dog and positions him/herself on the dog's right side. After a 3 second pause, the handler gives the dog the verbal command "sitz/sit". The dog must sit down quickly and straight.

(c) Evaluation:

Faulty build-up, stretching of the command, restless standing, taking steps in the direction of the handler, restlessness while the handler is returning, slow sitting down at the finish are to be evaluated accordingly. 5 points will be deducted if the dog sits or lies down upon receiving the verbal command "steh/stand".

(4.2.5) Retrieve On Flat – 10 points

(a) One verbal command each: "*bring*" / "*fetch*", "*aus*" / "*out*", "*fuss*" / "*heel*"

(b) Description of the Exercise:

From a basic position the handler throws a dumbbell (weight: 1000 g) about 10 paces far. The verbal command "bring/fetch" is not to be given until the dumbbell is lying completely still. The dog sits calmly and free next to the handler. Upon receiving the verbal command "bring/fetch", the dog is to run quickly and directly to the dumbbell, pick it up immediately and return it to the handler quickly and directly. The dog is to sit closely and straight in front of the handler. The handler must hold the dumbbell away from the dog with the command "aus/out". The handler must hold the dumbbell calmly in his/her right hand, with the right arm stretched-out alongside the right side of the body. On the verbal command "fuss/heel", the dog must quickly go into a basic position and sit straight on the handler's left side with the dog's shoulder blade level with the handler's knee. The handler is not permitted to change positions during the entire exercise.

(c) Evaluation:

Faulty basic position, slow go-out, faulty pick-up, slow coming back, dropping of the dumbbell, playing with the dumbbell or mouthing, splay-legged stance of the handler, faulty sit in front of the handler and faulty finish are to be evaluated accordingly.

Throwing the dumbbell too short, as well as help from the handler, without changing his/her position, leads to point deductions. If the handler leaves his/her position before the exercise is finished, the exercise will be rated "faulty". If the dog does not retrieve the dumbbell, the exercise will be evaluated with 0 points.

(4.2.6) Retrieve Over Hurdle (100 cm) – 15 points

(a) One verbal command each: "hopp" / "jump", "bring" / "fetch", "aus" / "out", "fuss" / "heel"

(b) Description of the Exercise:

The handler assumes a basic position with his/her dog in front of the hurdle, at a distance of at least 5 paces from the hurdle. From the basic position the handler throws a dumbbell (650 g) over the 100 cm high hurdle. The verbal command "bring/fetch" is not to be given until the dumbbell is lying completely still. The dog sits calmly and free next to the handler. Upon receiving the verbal commands "hopp/jump" and "bring/fetch" (the verbal command "bring/fetch" must be given while the dog is jumping over the hurdle) the dog is to jump over the hurdle, run quickly and directly to the dumbbell, pick it up immediately, turn around and jump over the hurdle and return the dumbbell to the handler quickly and directly. The dog is to sit closely and straight in front of the handler.

The dog is to hold the dumbbell calmly in his mouth until the handler, after a pause of about three seconds, takes the dumbbell away from the dog with the verbal command "aus/out". The handler must hold the dumbbell calmly in his/her right hand, with the right arm stretched-out alongside the right side of the body. On the verbal command "fuss/heel", the dog must quickly go into a basic position and sit straight on the handler's left side, with the dog's shoulder blade level with the handler's knee. The handler is not permitted to change positions during the entire exercise.

(c) Evaluation:

Faulty basic position, slow jump and go-out, faulty pick-up, slow coming back/return-jump, dropping of the dumbbell, playing with the dumbbell or mouthing, splay-legged stance of the handler, faulty sit in front of the handler and faulty finish are to be evaluated accordingly. For touching of the hurdle up to 1 point is to be deducted per jump. For stepping on the jump up to 2 points are to be deducted.

Distribution of points for retrieve over a hurdle:

Going-out jump	Retrieve	Return-jump
5 points	5 points	5 points

A partial score for the exercise is only possible if at least two out of the three parts of the exercise (going- out jump - retrieve – return jump) were completed.

Both jumps perfect, retrieve without faults = 15 points

Both jumps refused, retrieve without faults = 10 points

Both jumps perfect, dumbbell not retrieved = 10 points

If the dumbbell that is thrown by the handler lands too far over to one side or is poorly visible for the dog, the handler may ask the judge for permission to re-throw the dumbbell, or the judge may suggest a re-throw. No point deduction will result from this. The dog must remain sitting while this is going on.

Any handler-help without changing his/her position, is to be evaluated accordingly. If the handler leaves his/her position before the exercise is finished, the exercise is rated "faulty".

(4.2.7) Retrieve Over Scaling Wall (180 cm) – 15 points

(a) One verbal command each: *“hopp” / “jump”, “bring” / “fetch”, “aus” / “out”, “fuss” / “heel”*

(b) Description of the Exercise:

The handler assumes a basic position with his/her dog in front of the scaling wall, at a distance of at least 5 paces from the wall. From the basic position the handler throws a dumbbell (650g) over the scaling wall. The dog sits calmly and free next to the handler. Upon receiving the verbal commands *“hopp/jump”* and *“bring/fetch”* (the verbal command *“bring/fetch”* must be given while the dog is climbing over the wall) the dog must climb over the wall, run quickly and directly to the dumbbell, pick it up immediately, turn around and immediately climb back over the scaling wall and return the dumbbell quickly and directly. The dog is to hold the dumbbell calmly in his mouth until the handler, after a pause of about three seconds, takes the dumbbell away from the dog with the verbal command *“aus/out”*. The handler must hold the dumbbell calmly in his/her right hand, with the right arm stretched-out alongside the right side of the body. On the verbal command *“fuss/heel”*, the dog must quickly go into a basic position and sit straight on the handler’s left side, with the dog’s shoulder blade level with the handler’s knee. The handler is not permitted to change positions during the entire exercise.

(c) Evaluation:

Faulty basic position, slow jump and go-out, faulty pick-up, slow coming back/ return-jump, dropping of the dumbbell, playing with the dumbbell or mouthing, splay-legged stance of the handler, faulty sit in front of the handler and faulty finish are to be evaluated accordingly.

Distribution of points for retrieve over scaling wall:

Going-out jump	Retrieve	Return-jump
5 points	5 points	5 points

A partial score for the exercise is only possible if at least two out of the three parts of the exercise (going- out jump - retrieve – return jump) were completed.

Both jumps perfect, retrieve without faults = 15 points

Both jumps refused, retrieve without faults = 10 points

Both jumps perfect, dumbbell not retrieved = 10 points

If the dumbbell that is thrown by the handler lands too far over to one side or is poorly visible for the dog, the handler may ask the judge for permission to re-throw the dumbbell, or the judge may suggest a re-throw. No point deduction will result from this. The dog must remain sitting while this is going on.

Any handler-help without changing his/her position, is to be evaluated accordingly. If the handler leaves his/her position before the exercise is finished, the exercise is rated *“faulty”*.

(4.2.8) Send-Out With Down – 10 points

(a) One verbal command each: *“voraus” / “go out”, “platz” / “down”, “sitz” / sit”*

(b) Description of the Exercise:

From a basic position, the handler walks with his/her free-heeling dog in the direction prescribed by the judge. After 10-15 paces the handler gives the dog the verbal command *“voraus/go out”*. Simultaneously the handler lifts his/her

arm (only once) and stops. The dog must go out purposefully, at a fast pace and in a straight line at least 30 paces in the indicated direction. On the judge's signal, the handler gives the command "platz/down". The dog must down immediately. The handler may keep his/her arm raised until the dog lies down. On the judge's signal, the handler returns to his/her dog and locates him/herself on the dog's right side. After about three seconds the handler gives the dog the command "sitz/sit" and the dog must sit-up quickly and straight into a basic position.

(c) Evaluation:

Faulty build-up, the handler is following the dog, dog is going-out to slowly, strong deviation to the side, too short of a distance, too early or hesitant down, restless lying down or standing-up/sitting-up prematurely are to be evaluated accordingly.

(4.2.9) Long Down Under Distraction – 10 points

(a) One verbal command each: "platz" / "down", "sitz" / "sit"

(b) Description of the Exercise:

Before the beginning of another dog's obedience exercise in phase B, the handler downs his/her dog with the verbal command "platz/down", out of a basic position, in a spot designated by the judge, without leaving the leash or any type of article with the dog. Then, the handler walks about 30 paces away without turning around, within the boundaries of the exercise grounds and remains there, standing quietly in sight of the dog with his/her back towards the dog. The dog must calmly remain in the down position without any influence from the handler, while the other dog is performing exercise 1-7. On the judge's signal, the handler returns to the dog and positions him/herself on the dog's right side. After a brief pause of about three seconds the dog receives the command "sitz/sit". The dog is to sit-up quickly and straight into a basic position.

(c) Evaluation:

Restless behaviour of the handler or other hidden handler-help, restless lying down or premature standing-up/sitting-up when the handler returns are to be evaluated accordingly. If the dog sits-up or is standing but remains in the designated area, partial points will be given. If the dog removes itself from the designated area by more than 3 meters before the other dog has completed exercise #4, 0 points will be given for this exercise. If the dog leaves the designated area after exercise #4 is completed, partial points will be given. If the dog walks towards the handler when the handler is returning to the dog, up to 3 points may be deducted.

(4.3) IPO 1 – Phase C

Exercise 1:	Search for the helper	5 points
Exercise 2:	Hold and bark	10 points
Exercise 3:	Prevention of an attempted escape of the helper	10 points
Exercise 4:	Defence of the dog during guarding phase	20 points
Exercise 5:	Back-transport	5 points
Exercise 6:	Attack on the dog out of the Back-transport	30 points
Exercise 7:	Attack on the dog out of motion	20 points
Total		100 points

General Regulations:

In a suitable location six blinds are to be set-up along the length of the field, in a staggered fashion, three on each side (see sketch). Necessary markings must be clearly visible for the handler, the judge and the helper.

The helper must be equipped with a protection suit, sleeve and soft-stick. The sleeve must be equipped with a bite-bar and the sleeve-cover must be made from burlap (jute) in a natural colour. If it is necessary for the helper to keep a close eye on the dog during the guarding phase, the helper is not required to stand still, though he is not permitted to make any threatening or defensive movements. The helper must protect his body with the sleeve. It is up to the handler in which way he/she chooses to take the soft-stick away from the helper. (See also "General Information" page 9-12 – "Helper Regulations")

It is possible to work with only one helper at all examination levels. If more than 5 dogs are entered at the same examination level a second helper is mandatory. All dogs within the same examination level must be worked by the same helper/helpers.

Dogs that are out of control, that, after a defense exercise, do not release or release only after the handler takes physical measures (touches the dog), that bite other parts of the helper's body than the sleeve, must be disqualified. No TSB rating is given.

For dogs that fail during a defense exercise or get chased away, the protection phase is to be terminated. The dog does not receive a rating in the protection phase. However, the dog must receive a TSB rating.

The verbal command "aus/out" is permitted one time during all defense exercises. Evaluation for the "Out" see the table below.

Slow out	First additional command followed by immediate out	First additional command followed by slow out	Second additional command followed by immediate out	Second additional command followed by slow out	No out after Second additional command, respectively additional influence
0.5 - 3.0	3.0	3.5 - 6.0	6.0	6.5 - 9.0	Disqualification

(4.3.1) Search For The Helper – 5 points

- (a) One verbal command each: "*revier*" / "*search or voran*" / "*go-ahead*", "*hier*" / "*come*" (the verbal command "*hier/come*" may be given in conjunction with the dog's name)

- (b) Description of the Exercise:

The helper is located in the last blind, out of the dog's sight. The handler positions him/herself with his/her free-heeling dog between the second and third blind so that 4 side-sweeps are possible. On the judge's signal phase C begins. After the handler gives a brief verbal command "*revier/search*" in conjunction with a visual command, which is executed with either the right or left arm and may be repeated, the dog must quickly leave the handler and approach the prescribed blind purposefully and run around it closely and attentively. As soon as the dog has searched a blind, the handler gives the dog the verbal command "*hier/come*" (it is permissible to use the dog's name in conjunction with the command) and sends the dog, while he/she is in motion, by using the verbal command "*revier/search*", into the next blind. The handler is moving at a normal pace down an imaginary middle line. The handler is not permitted to leave this imaginary line during the search for the helper. The dog must be in front of the handler at all times. When the dog reaches the helper-blind the handler is required to stand still. At this point no further verbal commands are permitted.

- (c) Evaluation:
Limitations regarding manageability, fast and purposeful approach of the blinds as well as close and attentive running around the blind are to be deducted accordingly.

(4.3.2) Hold & Bark – 10 points

- (a) One verbal command each: *“hier” / “come”, “fuss” / “heel”*

- (b) Description of the Exercise:

The dog must confront the helper actively and attentively and bark continuously. The dog is not permitted to jump on or grip the helper. After the dog has barked for approximately 20 seconds, upon a signal from the judge, the handler approaches the blind and assumes position about 5 paces away from the blind. On the judge's signal, the handler calls his/her dog out of the blind into a basic position.

- (c) Evaluation:

Limitations regarding the continuous and demanding bark and forceful hold, not influenced by the judge or the approaching handler until the verbal command is given, are to be deducted accordingly. 5 points are given for continuous barking. For weak barking 2 points are deducted. If the dog does not bark but is guarding the helper actively, attentively and closely 5 points are deducted. Bothering of the helper, for example bumping, jumping up on the helper etc. leads to a deduction of up to 2 points. Up to 9 points may be deducted for heavy gripping. If the dog leaves the helper before the handler receives the signal from the judge to leave the middle line, the dog may be sent into the blind a second time.

If the dog stays with the helper this time, the protection phase may be continued, though the hold and bark is to be rated “insufficient”. If the dog does not want to cooperate or leaves the helper again, phase C is to be terminated. If the dog returns to the handler when he/she approaches the blind to pick-up the dog, or the dog returns to the handler prior to receiving the verbal command to do so, a partial score is given reflecting an insufficient rating.

(4.3.3) Prevention Of An Attempted Escape Of The Helper – 10 points

- (a) One verbal command each: *“fuss” / “heel”, “platz” / “down”, “aus” / “out”*

- (b) Description of the Exercise:

Upon a signal from the judge, the handler orders the helper to step out of the blind. The helper moves at a normal pace to the designated location for the escape. On a signal from the judge, the handler moves with his/her free-heeling dog to the designated location for the dog to down before the escape. The distance between dog and helper is 5 paces. The helper leaves his/her guarding dog in the down position and moves into the blind, maintaining visual contact with the dog, the helper and the judge. On the judge's signal the helper tries to escape.

The dog must immediately and independently prevent the escape effectively, without hesitation and by means of an energetic and strong grip. The dog may only bite the helper's sleeve. On the judge's signal the helper stands still. When the helper stops moving, the dog is to release immediately. The handler may give a verbal command “aus/out” on his/her own, within an adequate time.

If the dog does not release after the first command, the handler may give up to two additional commands “aus/out”, upon receiving a signal from the judge. If the dog does not release after having received three commands (one permissible and two additional commands) the team is to be disqualified. The handler has to stand calmly, without influencing the dog in any form, while giving the command “aus/out”. Upon releasing the helper, the dog must stay close to the helper and guard him attentively.

(c) Evaluation:

Limitations concerning important evaluation criteria are to be deducted accordingly. Fast and energetic response and pursuit in conjunction with a powerful engagement and effective prevention of the escape, full and calm grip until the release, attentive and close guarding of the helper. If the dog remains in the down position, or has not prevented the escape by means of biting and holding after the helper has taken about 20 steps, the protection phase is to be terminated.

If the dog is slightly inattentive and/or bothers the helper slightly during the guarding phase, the exercise will be marked down by one grade. If the dog is guarding the helper very inattentively and/or is bothering the helper very much, the exercise is marked down by two grades. If the dog is not guarding the helper but stays with him, the exercise is marked down by three grades. If the dog leaves the helper or if the handler gives a verbal command for the dog to stay with the helper, phase C is to be terminated..

(3.3.4) Defense Of The Dog During Guarding Phase – 20 points

(a) One verbal command each: *“aus” / “out”, “fuss” / “heel”*

(b) Description of the Exercise:

After a guarding phase of about 5 seconds, the helper makes an attack on the dog, on the judge's signal. Without any influence from the handler the dog must defend itself through energetic and powerful gripping. The dog may only grip the protective sleeve of the helper. As soon as the dog has a grip on the sleeve, the helper applies two stick-hits. Hits may only be applied to the shoulders and the area of the withers. Upon a signal from the judge the helper stands still.

After the helper has stopped the attack and is standing still, the dog must release immediately. The handler may give a verbal command *“aus/out”* on his own at the appropriate time.

If the dog does not out after having received the first permissible command, the handler may give up to two additional commands, upon receiving a signal from the judge. If the dog does not release after having received these commands (one permissible and two additional commands), the team is to be disqualified. The handler must stand still, without influencing the dog in any form, while giving the verbal command *“aus/out”*. After the dog releases, the dog must stay close to the helper and guard him attentively. Upon a signal from the judge, the handler walks directly to his/her dog at a normal pace and puts the dog with the verbal command *“fuss/heel”* in a basic position. The soft-stick is not taken from the helper.

(c) Evaluation:

Limitations concerning important evaluation criteria are to be deducted accordingly: Fast and powerful engagement, full and calm grip until the release, attentive and close guarding of the helper.

If the dog is slightly inattentive and/or bothers the helper slightly during the guarding phase, the exercise will be marked down by one grade. If the dog is guarding the helper very inattentively and/or is bothering the helper very much, the exercise is marked down by two grades. If the dog is not guarding the helper but stays with him, the exercise is marked down by three grades. If the dog comes towards the handler when he/she approaches, the exercise is rated *“insufficient”*. If the dog leaves the helper before the judge gives the signal to step-up or the handler gives a command for the dog to stay on the helper, the protection phase is terminated.

(4.3.5) Back-Transport– 5 points

(a) One verbal command: *“fuss” / “heel”*

(b) Description of the Exercise:

Exercise 4 is followed by the back-transport of the helper over a distance of about 30 paces. The course of the back-transport is prescribed by the judge. The handler instructs the helper to start walking. The handler follows the helper with his/her free-heeling dog, at a distance of about 5 paces. The dog is to watch the helper attentively. A distance of 5 paces to the helper must be maintained throughout the entire back-transport.

(c) Evaluation:

Limitations concerning important evaluation criteria are to be deducted accordingly:

Watching the helper attentively, exact heeling, maintaining a distance of 5 paces to the helper.

(4.3.6) Attack On Dog Out Of Motion – 30 points

(a) One verbal command each: “aus” / “out”, “fuss” / “heel”

(b) Description of the Exercise:

Out of the back-transport an attack is performed out of motion, on a signal from the judge. Without any influence from the handler and without hesitation, the dog is to counter the attack by means of an energetic and powerful grip. The dog may only bite the sleeve of the helper. As soon as the dog has a grip on the sleeve, the handler is to stand still. On a signal from the judge the helper stops the attack. As soon as the helper stands still, the dog is to release immediately. The handler may give a verbal command “aus/out” on his/her own at the appropriate time.

If the dog does not release after having received the first permissible verbal command, the handler may give up to two additional commands “aus/out”, upon receiving a signal from the judge. If the dog does not release after having received three commands (one permissible and two additional commands) the team is to be disqualified. While giving the verbal command “aus/out”, the handler is to stand still and is not allowed to influence the dog in any other form. After the dog releases, the dog is to stay close to the helper and guard him attentively. On a signal from the judge, the handler returns at a normal pace directly to his/her dog and puts the dog in a basic position with the verbal command “fuss/heel”. The soft-stick is taken from the helper.

A side-transport of the helper to the judge, over a distance of about 20 paces, follows. A verbal command “fuss/heel” is allowed. The dog must be positioned on the right side of the helper, so that the dog is between the helper and the handler. During the side-transport, the dog must watch the helper attentively. The dog may neither bother, jump-on nor grip the helper. The group stops in front of the judge, the handler presents the soft-stick to the judge and reports out.

(c) Evaluation:

Limitations regarding important evaluation criteria are to be deducted accordingly: Quick and powerful engagement, full and calm grip until the release, attentive and close guarding of the helper after releasing.

If the dog is slightly inattentive and/or bothering the helper slightly during the guarding phase, the exercise will be marked down by one grade. If the dog is guarding the helper very inattentively and/or is bothering the helper very much, the exercise is marked down by two grades. If the dog is not guarding the helper but stays with him, the exercise is marked down by three grades. If the dog moves towards the handler when he/she approaches, the exercise is rated “insufficient”. If the dog leaves the helper before the judge gives the signal to return to the dog or if the handler gives a verbal command for the dog to stay with the helper, phase C is to be terminated.

(4.3.7) Attack On The Dog Out Of Motion – 20 points

(a) One verbal command each: “sitz” / “sit”, “voran” or “pack-ihn” / “go ahead”, or “defend”, “aus” / “out”, “fuss” / “heel”

(b) Description of the Exercise:

The handler with his/her dog is sent to a marked spot on the centreline of the exercise ground, level with the first blind. The dog may be held by its collar but it is not permissible to stimulate the dog. On a signal from the judge the helper, who is equipped with a soft-stick, steps out of a blind and runs to the centreline. Once the helper has reached the centreline, he turns towards the handler and performs a frontal attack on handler and dog, without stopping or slowing down, while yelling and making strong threatening motions. As soon as the helper has reached a point about 40 to 50 paces away from the handler and the dog, the handler releases his/her dog, upon a signal from the judge, with the verbal command “voran/pack-ihn or go ahead/defend”. Upon receiving the command, the dog is to engage without hesitation and must prevent the attack by means of an energetic and strong grip. The dog may only grip the protective sleeve of the helper. The handler may not move from his/her position. On a signal from the judge, the helper stops the attack. After the helper has stopped the attack and is standing still, the dog must release immediately. The handler may give a verbal command “aus/out” on his/her own at the appropriate time.

If the dog does not release after receiving the first permissible command, the handler may give up to two additional commands “aus/out”, upon receiving a signal from the judge. If the dog does not release after receiving these commands (one permissible and two additional commands), the team is to be disqualified. The handler must stand still without influencing the dog in any other form while giving this command. After the dog releases, the dog must stay close to the helper and guard him attentively. Upon a signal from the judge, the handler walks directly to his/her dog at a normal pace and puts the dog with the verbal command “fuss/heel” in a basic position. The soft-stick is taken from the handler.

A side-transport of the helper to the judge over a distance of about 20 paces follows. A verbal command for “fuss/heel” is permitted. The dog must walk on the helper’s right side, so that the dog is in between the handler and the helper. During the back-transport the dog is to watch the helper closely. The dog may not bother nor jump on nor grip the helper during the back-transport. The group stops in front of the judge. The handler presents the soft-stick to the judge and reports out. Upon instruction by the judge, prior to the critique, the dog is put on a leash.

(c) Evaluation:

Limitations concerning important evaluation criteria are to be deducted accordingly: Quick and powerful engagement, full and calm grip until the release, attentive and close guarding of the helper.

If the dog is slightly inattentive and/or bothers the helper slightly during the guarding phase, the exercise will be marked down by one grade. If the dog is guarding the helper very inattentively and/or is bothering the helper very much, the exercise is marked down by two grades. If the dog is not guarding the helper but stays with him, the exercise is marked down by three grades. If the dog comes towards the handler when he/she approaches, the exercise is rated “insufficient”. If the dog leaves the helper before the judge gives the signal to step-up or the handler gives a verbal command for the dog to stay with the helper, phase “C” is to be terminated.

5. INTERNATIONAL TRIAL RULES IPO 3

is divided into:

Phase A	100 points
Phase B	100 points
Phase C	100 points
Total:	300 points

(5.1) IPO 3 – Phase A

- The track is laid by a stranger to the dog, minimum of 600 paces
- 5 legs, 4 corners (approximately 90 degrees), 3 articles
- at least 60 minutes old, 20 minutes to work-out the track

Staying on the track	80 points
Articles (10+10)	20 points
Total:	100 points

General Regulations:

The judge or the person in charge of tracking determines the pattern of the track, whereas the layout of the tracking field must be taken into consideration. Varying patterns must be used for the tracks. It is not permitted that the articles and corners on each track are placed at the same distance from each other. The start is to be marked clearly with a signpost. The marker is to be placed in the ground directly to the left of the scent pad.

Once more, the judge will draw for starting positions after the tracks are laid.

The tracklayer must show the tracking articles to the judge or the person in charge of tracking, prior to laying the track. Only well-scented articles (at least 30 minutes old) may be used. The tracklayer remains for a brief moment on the scent pad and then proceeds at a normal pace in the direction prescribed by the judge. The corners are likewise to be made at a normal pace. The first article is placed on the track after a minimum of 100 paces on the first or second leg. The second article is placed on the second or third leg and the third article is placed at the end of the last leg. The articles are to be laid on the track while the tracklayer is in motion. After placing the last article at the end of the last leg, the tracklayer must proceed to walk straight ahead for a few more paces. Different types of articles are to be used on the same track (materials: Leather, fabric, wood). The size of the articles may not exceed 10 cm in length, 2-3 cm in width and 0.5-1 cm in thickness. Their color may not stand out considerably from that of the terrain. All articles are to be marked with numbers. The numbers on the articles must coincide with the numbers on the signposts. Handler and dog must remain out of sight while the track is laid.

While the dog is working out the track, the judge, tracklayers and any accompanying persons are not permitted in the area of the track where the dog/handler team has the right to track.

(5.1.1) Verbal command : “such” / “seek”

The verbal command for “such/seek” is permitted at the start and after the 1st and 2nd article.

(5.1.2) Description of the Exercise:

The handler is preparing the dog for tracking. The dog may track free, off lead, or on a 10 m tracking line. While tracking, the 10 m tracking line may be placed across the back, on the side or between the front and/or hindquarters of the dog. The tracking line may be attached directly to the collar, dead ring, or to the ring on the tracking harness.

The following types of tracking harness are permitted: Breast-harness or Boettger-harness without any additional straps.

When called, the handler will report to the judge with the dog in a basic position. The handler will advise the judge whether the dog will pick-up or indicate the articles. Any forceful influence is to be avoided prior to tracking, at the start and during tracking.

On a signal from the judge, the dog is taken slowly and calmly to the starting point and is set onto the track. The dog is to take the scent at the start calmly and intensely with a deep nose. The dog must then proceed to track with a deep nose, maintaining a steady pace. The handler follows his/her dog at a distance of 10 m at the end of the tracking line. When tracking off lead, a distance of 10m must be maintained as well. A certain amount of slack in the line is permissible, as long as the handler keeps the tracking line in his/her hand. The dog must work out corners confidently. After working out a corner, the dog must continue to track at his regular pace.

As soon as the dog reaches an article it must immediately pick-up or indicate the article in a convincing manner, without help from the handler. The dog is permitted to stand, sit or return to the handler when picking-up an article. Moving forward with the article or picking-up the article while lying down is faulty. Indicating of the article may be done standing, sitting or lying down. It is permitted to alternate. As soon as the dog has indicated an article, the handler must lay down the tracking line and go to his/her dog. By raising the arm with the article in his/her hand, the handler shows that the dog has found the article. Then the handler picks-up the tracking line and handler and dog continue to work out the track. Upon completion of the track, the handler must show the articles that were found to the judge.

(5.1.3) Evaluation:

The speed with which the track is worked out is not a factor in the scoring, as long as the track is worked out intensely, evenly and convincingly and the dog shows a positive tracking attitude. A dog's checking to convince itself of the layout of the track is not faulty, as long as the dog does not leave the track. Aimless wandering, a high nose, urination/defecation, circling at the corners, continuous encouragement, leash-help or verbal help on the track or at the articles, missing pick-up/indication of the article and indicating a false object are faulty and will cause point deductions. The tracking work is to be terminated if the handler leaves the track by more than one line-length. If the dog goes to leave the track and the handler restrains him from doing so, the judge will instruct the handler to follow the dog. The tracking work is to be terminated if the handler fails to follow the judge's instruction. If the track is not completed within 20 minutes from the time the dog was put on the track, the judge will terminate the tracking work. The performance shown before the tracking work was terminated will be evaluated.

If a dog shows both options, in other words, if the dog indicates and picks-up the articles, while working out the articles, this is faulty. A rating is only given for articles that are indicated in the manner that was announced to the judge when the handler reported in. Faulty indication/pick-up of an article flows into the evaluation of the corresponding leg.

No points are given for articles that are not indicated/picked-up.

The distribution of points for each individual leg, for maintaining the track, has to reflect the length and the degree of difficulty. Each leg is evaluated in points and ratings. If the dog is not tracking (lingering in the same place and the dog is not tracking), the judge may terminate the tracking work even though the dog is still positioned on the track.

(5.2) IPO 2 – Phase B

Exercise 1:	Free heeling	10 points
Exercise 2:	Sit in motion	10 points
Exercise 3:	Down with recall	10 points
Exercise 4:	Stand In motion (walking)	10 points
Exercise 5:	Retrieve on the flat	10 points
Exercise 6:	Retrieve over hurdle	15 points
Exercise 7:	Retrieve over scaling wall	15 points
Exercise 8:	Send-out with down	10 points
Exercise 9:	Long down under distraction	10 points
Total		100 points

General Regulations:

The judge gives the signal to begin each exercise. Everything else such as about turns, halts, change of pace etc. will be carried out without signals from the judge. The verbal commands are described in the guidelines. Verbal commands are normally spoken, brief commands, consisting of one word. The commands may be given in any language. However, the same command is to be used for the same task at all times. If a dog does not perform the exercise or part of the exercise after receiving three commands, the exercise is to be terminated without a score. For the recall it is permissible to use the dog's name instead of the verbal command "hier/come". However, the name of the dog in conjunction with any verbal command is considered a double command.

In the basic position the dog is sitting closely and straight on the left hand side of the handler, whereas the dog's shoulder is level with the handler's knee. Each exercise begins and ends in a basic position. The basic position at the start of an exercise may only be assumed one time. Brief praising of the dog is permitted after each exercise is completed and only in a basic position. Upon praising the dog the handler may assume a new basic position. In any case, there must be a distinct pause (approximately 3 seconds) in between praising the dog and starting a new exercise.

An exercise is developed out of a basic position. The handler must show a minimum of 10 paces or a maximum of 15 paces before giving the verbal command for the execution of the exercise. Between all fronts and finishes, as well as the part where the handler returns to the sitting, standing or lying dog, a distinct pause (approximately 3 seconds) is to be observed. When the handler returns to the dog, he/she may do so by approaching the dog from the front or by going around behind the dog.

Correct free heeling is to be demonstrated at all times in between exercises. The dog must accompany the handler when he/she picks-up the dumbbells. It is not permitted to play or pump-up the dog while the handler retrieves the dumbbells.

The about turn is a left about turn. The dog may come around behind the handler or back-up from the front. However, it must be performed in the same manner throughout the trial. The dog may perform the finish by going around behind the handler or by executing a flip finish from in front of the handler.

The nonflexible hurdle is 100 cm high and 150 cm wide. The scaling wall consists of two parts connected at the top. The two sides of the wall are 150 cm wide and 191 cm high. The wall is to be positioned on the ground in such a manner that the vertical height is 180 cm. Both sides of the scaling wall must be covered with a non-skid material. Three cleats (approximately 24/48 mm) shall be attached to the upper part. All the dogs entered in a trial must jump over the same obstacles.

For the retrieve exercises only dumbbells are allowed. It is important to comply with the weight restrictions for the dumbbells (on flat ground – 2000gm – hurdle/scaling wall – 650gm). The dumbbells provided by the organizer are to be used by all participants. It is not permitted to place the dumbbell in the dog's mouth prior to the exercise.

If a handler forgets to perform an exercise, the judge will instruct the handler to perform the missing exercise. No points are deducted for this.

(5.2.1) Heeling Off Leash – 10 points

- (a) Verbal command: *"fuss" / "heel"*

The handler is permitted to use the command only when starting from a basic position and when changing pace.

- (b) Description of the Exercise:

Before starting the exercise the handler will approach the judge with his/her free-heeling dog. The handler will report to the judge. The dog should sit at heel during the reporting process. Out of a basic position the dog is to follow the handler attentively, happily and in a straight manner, upon receiving the command *"fuss/heel"* from the handler. The dog's shoulder blade must remain level with the handler's left knee. When the handler stops, the dog must sit down quickly and straight without any influence from the handler. At the start of the exercise handler and dog must walk 50 paces straight forward, without stopping. After demonstrating the about turn and 10-15 more paces the handler must show a fast and slow pace (at least 10 paces each). The transition from fast pace to slow pace is to be performed without any transitional steps in between. The two different paces must be distinctly different in speed. Then, at a normal pace, handler and dog must perform at least one right turn, one left turn and one about turn. A halt from a normal pace must be performed at least once.

While handler and dog walk down the first straight leg, two shots are fired (calibre 6 mm), five seconds apart. The shots are fired at a distance of at least 15 paces from the dog. The dog must remain indifferent to the gunshots. On instruction by the judge, at the end of the exercise, handler and dog walk through a moving group, consisting of at least four people. In the group, the handler must heel the dog around two persons, one to the left and one to the right and must halt at least once in the group. The judge is entitled to ask the handler to repeat the exercise. Handler and dog leave the group and assume a basic position.

- (c) Evaluation:

Forging, heeling wide, lagging, slow or hesitant sits, additional commands, physical help from the handler, inattentiveness at all paces and turns and/or an unhappy working attitude of the dog are to be evaluated accordingly.

(5.2.2) Sit In Motion – 10 points

- (a) One verbal command each: *"fuss/heel"*, *"sitz/sit"*

- (b) Description of the Exercise:

From the basic position the handler goes straight forward with his/her free-heeling dog. After 10-15 paces, the handler gives the command *"sitz/sit"* and the dog must sit down immediately in the direction of movement (straight) without the handler stopping, altering his/her pace or looking back at the dog. The handler goes on another 30 paces, then stops and turns immediately to face his/her calmly sitting dog. At the judge's signal, the handler returns to the dog and positions him/herself on the dog's right side.

- (c) Evaluation:

Faulty build-up, slow sitting down, restless and inattentive sitting are to be evaluated accordingly. 5 points will be deducted if the dog lies down or remains standing.

(5.2.3) Down With Recall – 10 points

(a) One verbal command each: *“fuss” / “heel”, “platz” / “down”, “hier” / “come”, “fuss” / “heel”*

(b) Description of the Exercise:

From a basic position the handler moves straight forward with his/her free-heeling dog. After 10-15 paces at a normal pace, followed by 10-15 paces at a running pace, the handler gives the dog the verbal command “platz/down”. The dog must lie down immediately and in the direction of movement (straight) without the handler stopping, altering his/her pace or looking back at the dog. The handler goes on another 30 paces, then stops and turns immediately to face his/her calmly lying dog. At the judge’s signal, the handler recalls the dog with the verbal command “hier/come” or the dog’s name. The dog must come in happily, quickly and directly and must sit closely and straight in front of the handler. On the verbal command “fuss/heel”, the dog must quickly go to sit straight beside the handler on the handler’s left side, whereas the dog’s shoulder blade is to be level with the handler’s knee.

(c) Evaluation:

Faulty build-up, slow downing, restless, slow recall or slowing down while approaching the handler, splay-legged stance of the handler, faulty sit in front of the handler and a faulty finish are to be evaluated accordingly. If the dog remains standing or sits after receiving the command “platz/down”, 5 points will be deducted.

(5.2.4) Stand In Motion (Walk) – 10 points

(a) One verbal command each: *“fuss” / “heel”, “steh” / “stand”, “sitz” / “sit”*

(b) Description of the Exercise:

From a basic position, the handler moves straight out, at a running pace, with his/her free-heeling dog. After 10-15 fast paces on the verbal command “steh/stand”, the dog must stand immediately and in the direction of movement (straight), without the handler slowing down or looking back. After 30 more paces the handler stops and turns immediately around to face his/her calmly standing dog. On the judge’s signal the handler recalls the dog with the command “hier/come” or the dog’s name. The dog is to come happily, quickly and directly to the handler and is to sit straight and close in front of the helper. Upon receiving the verbal command “fuss/heel”, the dog is to sit quickly and straight on the handler’s left side, whereas the dog’s shoulder blade is to be level with the handler’s knee.

(c) Evaluation:

Faulty build-up, stretching of the command, restless standing, taking steps in the direction of the handler, slow recall or slowing down while returning to the handler, splay-legged stance of the handler, faulty sitting in front and faulty finish are to be evaluated accordingly. 5 points will be deducted if the dog sits or lies down upon receiving the verbal command “steh/stand”.

(5.2.5) Retrieve On Flat – 10 points

(d) One verbal command each: *“bring” / “fetch”, “aus” / “out”, “fuss” / “heel”*

(e) Description of the Exercise:

From a basic position the handler throws a dumbbell (weight: 2000gm) about 10 paces far. The verbal command “bring/fetch” is not to be given until the dumbbell is lying completely still. The dog sits calmly and free next to the handler. Upon receiving the verbal command “bring/fetch”, the dog is to run quickly and directly to the dumbbell, pick it up immediately and return it to the handler quickly and directly. The dog is to sit closely and straight in front of the handler. The dog is to hold the dumbbell calmly in his mouth until the handler, after a pause of about three seconds, takes the dumbbell away from the dog with the command “aus/out”. The handler must hold the dumbbell calmly in his/her right hand, with the right arm stretched-out alongside the right side of the body. On the verbal command “fuss/heel”, the dog must quickly go into a basic position and sit straight on the handler’s left side, whereas the dog’s shoulder blade is to be level with the handler’s knee. The handler is not permitted to change positions during the entire exercise.

(f) Evaluation:

Faulty basic position, slow go-out, faulty pick-up, slow coming back, dropping of the dumbbell, playing with the dumbbell or mouthing, splay-legged stance of the handler, faulty sit in front of the handler and faulty finish are to be evaluated accordingly. Throwing the dumbbell too short, as well as help from the handler, without changing his/her position, leads to point deduction. If the handler leaves his/her position before the exercise is finished, the exercise will be rated “faulty”. If the dog does not retrieve the dumbbell, the exercise will be evaluated with 0 points.

(5.2.6) Retrieve Over Hurdle (100 cm) – 15 points

(a) One verbal command each: “hopp” / “jump”, “bring” / “fetch”, “aus” / “out”, “fuss” / “heel”

(b) Description of the Exercise:

The handler assumes a basic position with his/her dog in front of the hurdle, at a distance of at least 5 paces from the hurdle. From the basic position the handler throws a dumbbell (650 g) over the 100 cm high hurdle. The verbal command “hopp/jump” is not to be given until the dumbbell is lying completely still. The dog sits calmly and free next to the handler. Upon receiving the verbal commands “hopp/jump” and “bring/fetch” (the verbal command “bring/fetch” must be given while the dog is jumping over the hurdle) the dog is to jump over the hurdle, run quickly and directly to the dumbbell, pick it up immediately, turn around and jump over the hurdle and return the dumbbell to the handler quickly and directly. The dog is to sit closely and straight in front of the handler. The dog is to hold the dumbbell calmly in his mouth until the handler, after a pause of about three seconds, takes the dumbbell away from the dog with the verbal command “aus/out”. The handler must hold the dumbbell calmly in his/her right hand, with the right arm stretched-out alongside the right side of the body. On the verbal command “fuss/heel”, the dog must quickly go into a basic position and sit straight on the handler’s left side, whereas the dog’s shoulder blade is to be level with the handler’s knee. The handler is not permitted to change positions during the entire exercise.

(c) Evaluation:

Faulty basic position, slow jump and go-out, faulty pick-up, slow coming back/return-jump, dropping of the dumbbell, playing with the dumbbell or mouthing, splay-legged stance of the handler, faulty sit in front of the handler and faulty finish are to be evaluated accordingly. For touching of the hurdle up to 1 point is to be deducted per jump. For stepping on the jump up to 2 points are to be deducted.

Distribution of points for retrieve over a hurdle:

Going-out jump	Retrieve	Return-jump
5 points	5 points	5 points

A partial score for the exercise is only possible if at least two out of the three parts of the exercise (going- out jump - retrieve – return jump) were completed.

Both jumps perfect, retrieve without faults = 15 points

Both jumps refused, retrieve without faults = 10 points

Both jumps perfect, dumbbell not retrieved = 10 points

If the dumbbell, after it is thrown by the handler, lands too far over to one side or is poorly visible for the dog, the handler may ask the judge for permission to re-throw the dumbbell, or the judge may suggest a re-throw. No point deduction will result from this. The dog must remain sitting while this is going on.

Any help from the handler, without changing his/her position, is to be evaluated accordingly. If the handler leaves his/her position before the exercise is finished, the exercise is rated “faulty”.

(5.2.7) Retrieve Over Scaling Wall (180 cm) – 15 points

(a) One verbal command each: “*hopp*” / “*jump*”, “*bring*” / “*fetch*”, “*aus*” / “*out*”, “*fuss*” / “*heel*”

(b) Description of the Exercise:

The handler assumes a basic position with his/her dog in front of the scaling wall, at a distance of at least 5 paces from the wall. From the basic position the handler throws a dumbbell (650 g) over the scaling wall. The dog sits calmly and free next to the handler. Upon receiving the verbal commands “*hopp/jump*” and “*bring/fetch*” (the verbal command “*bring/fetch*” must be given while the dog is climbing over the wall) the dog must climb over the wall, run quickly and directly to the dumbbell, pick it up immediately, turn around and immediately climb back over the scaling wall and return the dumbbell quickly and directly. The dog is to hold the dumbbell calmly in his mouth until the handler, after a pause of about three seconds, takes the dumbbell away from the dog with the verbal command “*aus/out*”. The handler must hold the dumbbell calmly in his/her right hand, with the right arm stretched-out alongside the right side of the body. On the verbal command “*fuss/heel*”, the dog must quickly go into a basic position and sit straight on the handler’s left side, whereas the dog’s shoulder blade is to be level with the handler’s knee. The handler is not permitted to change positions during the entire exercise.

(c) Evaluation:

Faulty basic position, slow jump and go-out, faulty pick-up, slow coming back/return-jump, dropping of the dumbbell, playing with the dumbbell or mouthing, splay-legged stance of the handler, faulty sit in front of the handler and faulty finish are to be evaluated accordingly.

Distribution of points for retrieve over scaling wall:

Going-out jump	Retrieve	Return-jump
5 points	5 points	5 points

A partial score for the exercise is only possible if at least two out of the three parts of the exercise (going- out jump - retrieve – return jump) were completed.

Both jumps perfect, retrieve without faults = 15 points

Both jumps refused, retrieve without faults = 10 points

Both jumps perfect, dumbbell not retrieved = 10 points

If the dumbbell, after it is thrown by the handler, lands too far over to one side or is poorly visible for the dog, the handler may ask the judge for permission to re-

throw the dumbbell, or the judge may suggest a re-throw. No point deduction will result from this. The dog must remain sitting while this is going on.

Any help from the handler, without changing his/her position, is to be evaluated accordingly. If the handler leaves his/her position before the exercise is finished, the exercise is rated "faulty".

(5.2.8) Send-Out With Down – 10 points

(a) One verbal command each: "*voraus*" / "*go out*", "*platz*" / "*down*", "*sitz*" / "*sit*"

(b) Description of the Exercise:

From a basic position the handler walks with his/her free-heeling dog in the direction he/she has been instructed to go by the judge. After 10-15 paces the handler gives the dog the verbal command "*voraus/go out*" and stands still. Simultaneously the handler lifts his/her arm (only once) and stops. The dog must go out purposefully, at a fast pace and in a straight line at least 30 paces in the indicated direction. On the judge's signal, the handler gives the verbal command "*platz/down*". The dog must down immediately. The handler may keep his/her arm raised until the dog downs. On the judge's signal, the handler returns to his/her dog and locates him/herself on the dog's right side. After about three seconds the handler gives the dog the verbal command "*sitz/sit*" and the dog must sit-up quickly and straight into a basic position.

(c) Evaluation:

Faulty build-up, the handler is following the dog, dog is going-out too slowly, strong deviation to the side, too short of a distance, too early or hesitant lying down, restless lying down or standing-up/sitting-up prematurely when the handler approaches the dog are to be evaluated accordingly.

(5.2.9) Long Down Under Distraction – 10 points

(a) One verbal command each: "*platz*" / "*down*", "*sitz*" / "*sit*"

(b) Description of the Exercise:

Before the beginning of another dog's obedience exercise in phase B, the handler downs his/her dog with the verbal command "*platz/down*" out of a straight basic position, in a spot designated by the judge, without leaving the leash or any type of article with the dog. Then, the handler walks a minimum of 30 paces away from the dog, without turning around, within the boundaries of the exercise grounds and moves out of sight. The dog must calmly remain in the down position without any influence from the handler, while the other dog is performing exercises 1-7. On the judge's signal the handler returns to the dog and positions him/herself on the dog's right side. After a brief pause of about three seconds, the dog receives the command "*sitz/sit*". The dog is to sit-up quickly and straight into a basic position.

(c) Evaluation:

Restless behaviour of the handler or other hidden handler-help, restless lying down or premature standing-up/sitting-up when the handler returns are to be evaluated accordingly. If the dog sits-up or is standing but remains in the designated area, partial points will be given. If the dog removes itself from the designated area by more than 3 meters before the other dog has completed exercise #5, 0 points will be given for this exercise. If the dog leaves the designated area after exercise #5 is completed, partial points will be given.

If the dog walks towards the handler when the handler is returning to the dog, up to 3 points may be deducted.

(5.3) IPO 1 – Phase C

Exercise 1:	Search for the helper	10 points
Exercise 2:	Hold and bark	10 points
Exercise 3:	Prevention of an attempted escape of the helper	10 points
Exercise 4:	Defence of the dog during guarding phase	20 points
Exercise 5:	Back-transport	5 points
Exercise 6:	Attack on the dog out of the Back-transport	15 points
Exercise 7:	Attack on the dog out of motion	10 points
Exercise 8:	Defence of the dog out of the guarding phase	20 points
Total		100 points

General Regulations:

In a suitable location six blinds are to be set-up along the length of the field, in a staggered fashion, three on each side (see sketch). Necessary markings must be clearly visible for the handler, the judge and the helper.

The helper must be equipped with a protection suit, sleeve and soft-stick. The sleeve must be equipped with a bite-bar and the sleeve-cover must be made from burlap (jute) in a natural colour. If it is necessary for the helper to keep a close eye on the dog during the guarding phase, the helper is not required to stand still, though he is not permitted to make any threatening or defensive movements. The helper must protect his body with the sleeve. It is up to the handler in which way he/she chooses to take the soft-stick away from the helper. (See also "General Information" pages 9-12 – "Helper Regulations")

It is possible to work with only one helper at all examination levels. If more than 5 dogs are entered at the same examination level a second helper is mandatory. All dogs within the same examination level must be worked by the same helper/helpers.

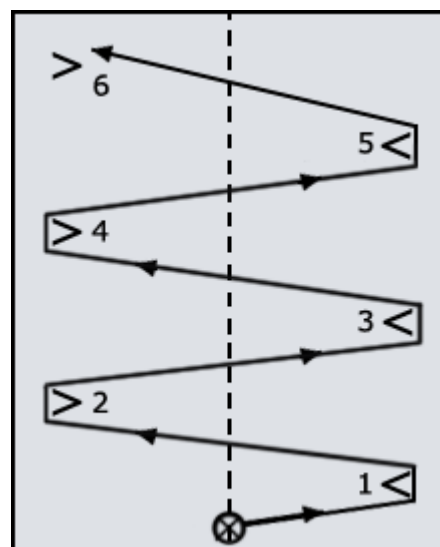

Dogs that are out of control, that after a defense exercise do not release or release only after the handler takes physical measures (touches the dog), that bite other parts of the helper's body than the sleeve, must be disqualified. No TSB rating is given.

For dogs that fail during a defense exercise or get chased away, the protection phase is to be terminated. The dog does not receive a rating in the protection phase. However, the dog must receive a TSB rating.

The verbal command “aus/out” is permitted one time during all defense exercises. Evaluation for the “out” see the table below.

Slow out	First additional command followed by immediate out	First additional command followed by slow out	Second additional command followed by immediate out	Second additional command followed by slow out	No out after Second additional command, respectively additional influence
0.5 - 3.0	3.0	3.5 - 6.0	6.0	6.5 - 9.0	Disqualification

(5.3.1) Search For The Helper – 10 points

- (a) One verbal command each: “*revier*” / “*search* or “*voran*” / “*go-ahead*”, “*hier*” / “*come*” (the verbal command “*hier/come*” may be given in conjunction with the dog’s name)

- (b) Description of the Exercise:

The helper is located in the last blind, out of the dog’s sight. The handler positions him/herself with his/her dog in front of the first blind so that six side-sweeps are possible. On the judge’s signal phase C begins. After the handler gives a brief verbal command “*revier/search*” in conjunction with a visual command, which is executed with either the right or left arm and may be repeated, the dog must quickly leave the handler and approach the prescribed blind purposefully and run around it closely and attentively.

As soon as the dog has searched a blind, the handler gives the dog the verbal command “*hier/come*” and sends the dog while he/she is in motion, by using the verbal command “*revier/search*” into the next blind. The handler is moving at a normal pace down an imaginary middle line. The handler is not permitted to leave this imaginary line during the search for the helper. The dog must be in front of the handler at all times. When the dog reaches the helper-blind the handler is required to stand still. At this point no further verbal commands are permitted.

- (c) Evaluation:

Limitations regarding manageability, fast and purposeful approach of the blinds as well as close and attentive running around the blind are to be deducted accordingly.

(5.3.2) Hold & Bark – 10 points

- (a) One verbal command each: “*hier*” / “*come*”, “*fuss*” / “*heel*”

- (b) Description of the Exercise:

The dog must confront the helper actively and attentively and bark continuously. The dog is not permitted to jump on or grip the helper. After the dog has barked for about 20 seconds, upon a signal from the judge, the handler approaches the blind and assumes position about 5 paces away from the blind. On the judge’s signal, the handler calls his/her dog out of the blind into a basic position..

- (c) Evaluation:

Limitations regarding the continuous and demanding bark and forceful hold, not influenced by the judge or the approaching handler until the verbal command is given, are to be deducted accordingly. 5 points are given for continuous barking. For weak barking 2 points are deducted. If the dog does not bark but is guarding the helper actively, attentively and closely 5 points are deducted. Bothering of the helper, for example bumping, jumping up on the helper etc. leads to a deduction of up to 2 points. Up to 9 points may be deducted for heavy gripping. If the dog leaves the helper before the handler receives the signal from the judge to leave the middle line, the dog may be sent into the blind a second time.

If the dog stays with the helper this time, the protection phase may be continued, though the hold and bark is to be rated "insufficient". If the dog does not want to cooperate or leaves the helper again, phase C is to be terminated. If the dog returns to the handler when he/she approaches the blind to pick-up the dog, or the dog returns to the handler prior to receiving a verbal command to do so, a partial score is given reflecting an "insufficient" rating.

(5.3.3) Prevention Of An Attempted Escape Of The Helper – 10 points

(a) One verbal command each: *"fuss" / "heel", "platz" / "down", "aus" / "out"*

(b) Description of the Exercise:

Upon a signal from the judge, the handler orders the helper to step out of the blind. The helper moves at a normal pace to the designated location for the escape. On a signal from the judge, the handler moves with his/her free-heeling dog to the designated location for the dog to down before the escape.

The distance between dog and helper is 5 paces. The handler leaves his/her guarding dog and moves into the blind, maintaining visual contact with the dog, the judge and the helper. On the judge's signal the helper tries to escape. The dog must immediately and independently prevent the escape without hesitation and by means of an energetic and strong grip. The dog may only bite the helper's sleeve. On the judge's signal the helper stands still. When the helper stops moving the dog is to release immediately. The handler may give a verbal command "aus/out" on his own, within an appropriate time.

If the dog does not release after the first command, the handler may give up to two additional commands "aus/out", upon receiving a signal from the judge. If the dog does not release after having received three commands (one permissible and two additional commands) the team is to be disqualified. The handler has to stand calmly, without influencing the dog in any form, while giving the verbal command "aus/out". Upon releasing the helper the dog must stay close to the helper and guard him attentively.

(c) Evaluation:

Limitations concerning important evaluation criteria are to be deducted accordingly: Fast and energetic response and pursuit in conjunction with a powerful engagement and effective prevention of the escape, full and calm grip until the release, attentive and close guarding of the helper. If the dog remains lying or sitting, or has not prevented the escape by means of biting and holding after the helper has taken about 20 steps, the protection phase is to be terminated.

If the dog is slightly inattentive and/or bothers the helper slightly during the guarding phase, the exercise will be marked down by one grade. If the dog is guarding the helper very inattentively and/or bothers the helper very much, the exercise is marked down by two grades. If the dog is not guarding the helper but stays with him, the exercise is marked down by three grades. If the dog leaves the helper or if the handler gives a verbal command for the dog to stay with the helper, Phase C is to be terminated.

(5.3.4) Defense Of The Dog During Guarding Phase – 20 points

(a) One verbal command each: *"aus" / "out", "fuss" / "heel"*

(b) Description of the Exercise:

After a guarding phase of about 5 seconds the helper makes an attack on the dog, on the judge's signal. Without any influence from the handler the dog must defend itself through energetic and powerful gripping. The dog may only bite the protective sleeve of the helper. As soon as the dog has a grip on the sleeve, the helper applies two stick-hits. Hits may only be applied to the shoulders and the area of the withers. Upon a signal from the judge, the helper stands still. After the helper has stopped the attack and is standing still, the dog must out

immediately. The handler may give a verbal command “aus/out” on his own at the appropriate time.

If the dog does not release after having received the first permissible command, the handler may give up to two additional commands “aus/out”, upon receiving a signal from the judge. If the dog does not release after having received these commands (one permissible and two additional commands), the team is to be disqualified. The handler must stand still without influencing the dog in any form, while giving the verbal command “aus/out”. After the dog releases, the dog must stay close to the helper and guard him attentively. Upon a signal from the judge, the handler walks directly to his/her dog at a normal pace and puts the dog with the verbal command “fuss/heel” in a basic position. The soft-stick is not taken from the helper.

(c) Evaluation:

Limitations concerning important evaluation criteria are to be deducted accordingly: Fast and powerful engagement, full and calm grip until the release, attentive and close guarding of the helper. If the dog is slightly inattentive and/or bothers the helper slightly during the guarding phase, the exercise will be marked down by one grade.

If the dog is guarding the helper very inattentively and/or is bothering the helper very much, the exercise is marked down by two grades. If the dog is not guarding the helper but stays with him, the exercise is marked down by three grades. If the dog moves towards the handler when he/she approaches, the exercise is rated “insufficient”. If the dog leaves the helper before the judge gives the signal to step-up or the handler gives a command for the dog to stay with the helper, the protection phase is terminated.

(5.3.5) Back-Transport– 5 points

(a) One verbal command: “fuss” / “heel”

(b) Description of the Exercise:

Exercise 4 is followed by the back-transport of the helper over a distance of about 30 paces. The course of the back-transport is prescribed by the judge. The handler instructs the helper to start walking. The handler follows the helper with his/her free-heeling dog at a distance of about 5 paces. The dog is to watch the helper attentively. A distance of 5 paces to the helper must be maintained throughout the entire back-transport.

(c) Evaluation:

Limitations concerning important evaluation criteria are to be deducted accordingly: Watching the helper attentively, exact heeling, maintaining a distance of 5 paces to the helper..

(5.3.6) Attack On The Dog Out Of The Back-Transport – 15 points

(a) One verbal command each: “aus” / “out”, “fuss” / “heel”

(b) Description of the Exercise:

Out of the back-transport an attack is performed out of motion, on a signal from the judge. Without any influence from the handler and without hesitation, the dog is to counter the attack by means of an energetic and powerful grip. The dog may only bite the sleeve of the helper. As soon as the dog has a grip on the sleeve, the handler is to stand still. On a signal from the judge the helper stops the attack. As soon as the helper stands still the dog is to release immediately. The handler may give a verbal command “aus/out” on his/her own at the appropriate time.

If the dog does not release after having received the first permissible verbal command, the handler may give up to two additional commands “aus/out”, upon receiving a signal from the judge. If the dog does not release after having

received three commands (one permissible and two additional commands) the team is to be disqualified. The handler must stand still while giving the verbal command "aus/out" and is not allowed to influence the dog in any other form. After the dog releases, the dog is to stay close to the helper and guard him attentively. On a signal from the judge, the handler returns directly to his/her dog and puts the dog with the verbal command "fuss/heel" in a basic position. The soft-stick is taken from the helper.

A side-transport of the helper to the judge, over a distance of about 20 paces, follows. A verbal command "fuss/heel" is allowed. The dog must be positioned on the right side of the helper, so that the dog is between the helper and the handler. During the side-transport, the dog must watch the helper attentively. The dog may neither bother, jump-on nor grip the helper. The group stops in front of the judge, the handler presents the soft-stick to the judge and reports out.

(c) Evaluation:

Limitations regarding important evaluation criteria are to be deducted accordingly: Quick and powerful engagement, full and calm grip until the release, attentive and close guarding of the helper after releasing.

If the dog is slightly inattentive and/or bothers the helper slightly during the guarding phase, the exercise will be marked down by one grade. If the dog is guarding the helper very inattentively and/or bothers the helper very much, the exercise is marked down by two grades. If the dog is not guarding the helper but stays with him, the exercise is marked down by three grades. If the dog moves towards the handler when he/she approaches, the exercise is rated "insufficient". If the dog leaves the helper before the judge gives the signal to return to the dog or if the handler gives a verbal command for the dog to stay with the helper, Phase C is to be terminated..

(5.3.7) Attack On The Dog Out Of Motion – 10 points

(a) One verbal command each: "sitz" / "sit", "voran" or "pack-ihn" / "go ahead" or "defend", "aus" / "out"

(b) Description of the Exercise:

The handler with his/her dog is sent to a marked spot on the centreline of the exercise ground, level with the first blind. The dog may be held by its collar but it is not permissible to stimulate the dog. On a signal from the judge the helper, who is equipped with a soft-stick, steps out of the blind and runs to the centreline. Once the helper has reached the centreline, he turns towards the handler and performs a frontal attack on the handler and the dog, without stopping or slowing down, while yelling and making strong threatening motions. As soon as the helper has reached a point about 60 paces away from the handler and the dog, the handler releases his/her dog upon a signal from the judge, with the verbal command "voran/pack-ihn or go ahead/defend". Upon receiving the command, the dog is to engage without hesitation and must prevent the attack by means of an energetic and strong grip. The dog may only grip the protective sleeve of the helper. The handler may not move from his/her position. On a signal from the judge, the helper stops the attack. After the helper has stopped the attack and is standing still, the dog must release immediately. The handler may give a verbal command "aus/out" on his/her own at the appropriate time.

If the dog does not release after receiving the first permissible command, the handler may give up to two additional commands "aus/out", upon receiving a signal from the judge. If the dog does not release after receiving these commands (one permissible and two additional commands), the team is to be disqualified. The handler must stand still without influencing the dog in any other form while giving the verbal command "aus/out". After the dog releases, the dog must stay close to the helper and guard him attentively.

(c) Evaluation:

Limitations concerning important evaluation criteria are to be deducted accordingly: energetic defense in conjunction with a powerful engagement, full and calm grip until the release, attentive and close guarding of the helper.

If the dog is slightly inattentive and/or bothers the helper slightly during the guarding phase, the exercise will be marked down by one grade. If the dog is guarding the helper very inattentively and/or is bothering the helper very much, the exercise is marked down by two grades. If the dog is not guarding the helper but stays with him, the exercise is marked down by three grades. If the dog leaves the helper or the handler gives a command for the dog to stay with the helper, Phase C is to be terminated.

(5.3.8) Defense Of The Dog Out Of The Guarding Phase – 20 points

(a) One verbal command each: *“aus” / “out”, “fuss” / “heel (finish)”, “fuss” / “heel”*

(b) Description of the Exercise:

After a guarding phase of about five seconds, and upon a signal from the judge, the helper makes an attack on the dog. Without any influence from the handler and without hesitation, the dog must defend itself through energetic and powerful gripping. The dog may only grip the protective sleeve of the helper. Once the dog is gripping the sleeve, the dog receives two stick hits. The stick hits may only be applied to the shoulders and the area of the withers. Upon a signal from the judge, the helper stops and stands still. The dog is to release immediately after the helper stands still. The handler may give a verbal command *“aus/out”*, on his/her own at the appropriate time.

If the dog does not release after receiving the first permissible command, the handler may give up to two additional commands *“aus/out”*, upon receiving a signal from the judge. If the dog does not release after having received these commands (one permissible and two additional commands), the team is to be disqualified. The handler must stand still, without influencing the dog in any other form, while giving the verbal command *“aus/out”*. After the dog releases, the dog must stay close to the helper and guard him attentively. Upon a signal from the judge, the handler goes directly and at a normal pace to his/her dog and puts the dog with the verbal command *“fuss/heel”* in a basic position. The soft-stick is taken from the helper.

This is followed by a side-transport of the helper to the judge over a distance of about 20 paces. A verbal command *fuss/heel”* is allowed. The dog must walk on the helper's right side, so that the dog is positioned between the handler and the helper. During the side-transport the dog may neither bother, jump on nor grip the helper. The group stops in front of the judge. The handler presents the soft-stick to the judge and reports out. Prior to the critique and upon an order from the judge, the dog is put on a leash..

(c) Evaluation:

Limitations concerning important evaluation criteria are to be deducted accordingly: Quick and powerful engagement, full and calm grip until the release, attentive and close guarding of the helper. If the dog is slightly inattentive and/or bothers the helper slightly during the guarding phase, the exercise will be marked down by one grade. If the dog is guarding the helper very inattentively and/or is bothering the helper very much, the exercise is marked down by two grades. If the dog is not guarding the helper but stays with him, the exercise is marked down by three grades. If the dog moves towards the handler when he/she approaches, the exercise is rated *“insufficient”*. If the dog leaves the helper before the judge gives the signal to step-up, or the handler gives a command for the dog to stay with the helper, the protection phase is terminated.

6. TRACKING DOG EXAMINATION IPO – FH

- Two tracks, laid by a stranger, each consisting of 1800 paces
- 8 legs, 7 corners, 7 articles + 1 identification-article (no points)
- 120 minutes old, cross-track, 45 minutes to work out each track.

	1st day	2nd day	Total
Staying on the track	80 points	80 points	160 points
Articles (10+10)	20 points	20 points	40 points
Total:	100 points	100 points	200 points

General Regulations:

The judge or the person in charge of tracking determines the pattern of the track, whereas the layout of the tracking field must be taken into consideration. The tracks must be laid on two separate days. Varying patterns must be used for the tracks. It is not permitted that the articles and corners on each track are placed at the same distance from each other.

Two tracks for each participant must be laid on two consecutive days, in two separate locations and by different tracklayers.

The judge will draw once more for starting positions after the tracks are laid.

The tracklayer must show the tracking articles to the judge or the person in charge of

tracking, prior to laying the track. Only well-scented articles (at least 30 minutes old) may be used. The starting field is an imaginary area of 20 x 20 meters in size. The base line of the starting field (square) is marked by means of two markers. The tracklayer enters the starting field from about the middle of one of the two sidelines and deposits the identification article within the area of the starting field. The identification article marks the actual starting point of the track. The identification article is of the same size and makeup as the articles used on the track. The tracklayer remains for a brief moment on the scent pad and then proceeds at a normal pace in the direction prescribed by the judge, while crossing the opposite side of the base line. The legs of the track must accommodate the layout of the tracking field. One of the legs must prescribe a half-circle, with a radius of at least three tracking-lines (about 30 m). The half-circle begins and ends with a right corner. The seven corners are laid at a normal pace and must accommodate the layout of the tracking field. At least two of the seven corners must be acute angles, ranging between 30 and 60 degrees. The various articles (materials: leather, fabric, wood) may be distributed unevenly on the track. The last article must be placed at the end of the last leg. The articles are to be placed on the track while the tracklayer is in motion.

After placing the last article at the end of the last leg, the tracklayer must proceed to walk straight ahead for a few more paces. The size of the articles may not exceed 10 cm in length, 2-3 cm in width and 0.5-1 cm in thickness. Their colour may not stand out considerably from that of the terrain. All articles are to be marked with numbers. The numbers on the articles must coincide with the number of the track. Handler and dog must remain out of sight while the track is laid. 30 minutes prior to the start, a second tracklayer is to lay a cross-track, which must go across two of the track's legs, in an angle no lesser than 60 degrees. The cross-track may not cross the first or last leg, or cross the same leg twice. While the dog is working out the track, the judge, tracklayers and any accompanying persons are not permitted in the area of the track where the team (dog and handler) has the right to track.

(6.1.1) Verbal command : “such” / “seek”

The verbal command “such/seek” is permitted at the start and after each article. A certain amount of praise as well as a certain number of additional commands to “such/seek” are permitted. Additional commands are not permitted while working out corners or while approaching the articles.

(6.1.2) Description of the Exercise:

The handler is preparing the dog for tracking. The dog may track free, off lead, or on a 10 m tracking line. While tracking, the 10 m tracking line may be placed across the back, on the side or between the front and/or hindquarters of the dog. The tracking line may be attached directly to the collar, dead ring, or to the ring on the tracking harness. (The following types of tracking harness are permitted: Breast-harness or Boettger-harness without any additional straps). When called, the handler will report to the judge with the dog in a basic position. The handler will advise the judge whether the dog will pick-up or indicate the articles. The judge will advise the handler from which side he/she is to take the dog to the starting field. Any forceful influence is to be avoided prior to tracking, at the start and during tracking. On a signal from the judge the dog is taken slowly and calmly to the start-line. The handler may not step onto the starting field until the 10 m tracking-line has run out. The time allotted for the dog to locate the identification-article and to start working out the track is limited to three minutes. Once the dog has located the identification-article, it is to follow the track intensely, calmly and with a deep nose, while maintaining a steady pace.

The handler follows his/her dog at the end of the 10 m tracking line. When tracking off lead, the handler must also maintain a distance of 10 m between the handler and the dog. A certain amount of slack in the line is permissible, as long as the handler keeps the tracking line in his/her hand. The dog must work out corners confidently. After working out a corner, the dog must continue to track at his regular pace. As soon as the dog reaches an article it must immediately pick-up or indicate the article in a convincing manner, without help from the handler. The dog is permitted to stand, sit or return to the handler when picking-up an article. Moving forward with the article or picking-up the article while lying down is faulty. Indicating of the article may be done standing, sitting or lying down (it is permissible to alternate). As soon as the dog has indicated/picked-up an article, the handler must go to his/her dog. By raising the arm with the article in his/her hand, the handler shows that the dog has found the article. Then handler and dog continue to track.

Upon completion of the track, the handler must show the articles that were found to the judge. It is not permitted to dispense food while tracking. The handler is allowed, upon consulting the judge, to interrupt the tracking work briefly if he/she believes that he/she or the dog is in need of a brief break, on grounds of physical conditions or weather conditions (i.e. extreme heat). The time taken for such a break is deducted from the total time that is available to work out the track. The handler is allowed to clean the dog's head, eyes and nose during a break or at an article. For this purpose, the handler is allowed to carry a moist cloth or sponge with him/her. These items must be shown to the judge prior to the start of the tracking work. Any additional aid is not permitted.

(6.1.3) Evaluation:

To obtain a passing score, at least 70 points must be earned on each track. No points are given for the search and indication of the identification-article. The scoring starts once the dog has taken-up the scent of the track. The speed with which the track is worked out is not a factor in the scoring, as long as the track is worked out intensely, evenly and convincingly and the dog shows a positive tracking attitude. A dog's checking to convince itself of the layout of the track is not faulty, as long as the dog does not leave the track. Re-starting, aimless wandering, a high nose, urination/defecation, circling at the corners, continuous encouragement, leash-help or verbal help on the track or at the articles, missing pick-up/indication of the article and indicating a false object are faulty and will cause point deductions. The tracking work is to be terminated if the handler leaves the track by more than one line-length.

If the dog goes to leave the track and the handler restrains him from doing so, the judge will instruct the handler to follow the dog. The tracking work is to be terminated if the handler fails to follow the judge's instruction. If the dog has not reached the end of the track within 45 minutes after the start, the judge terminates the tracking work. An exception is made if the dog is working out the last leg of the track. In that case, the judge cannot terminate the tracking work for exceeding the time limit. The performance shown before the tracking work was terminated will be evaluated.

It is faulty if a dog shows both options, in other words, if the dog indicates and picks-up the articles. A rating is only given for articles that are indicated in the manner that was announced to the judge when the handler reported in. Faulty indication/pick-up of an article flows into the evaluation of the corresponding leg. Missed articles must not be shown to the handler.

No points are given for articles that were not indicated or picked-up. The distribution of points for maintaining the track, for each individual leg, has to reflect the length and the degree of difficulty. Each leg is evaluated in points and ratings. If the dog is not tracking (lingering in the same place and the dog is not tracking), the judge may terminate the tracking work even though the dog is still positioned on the track.

7. IPO EQUIPMENT

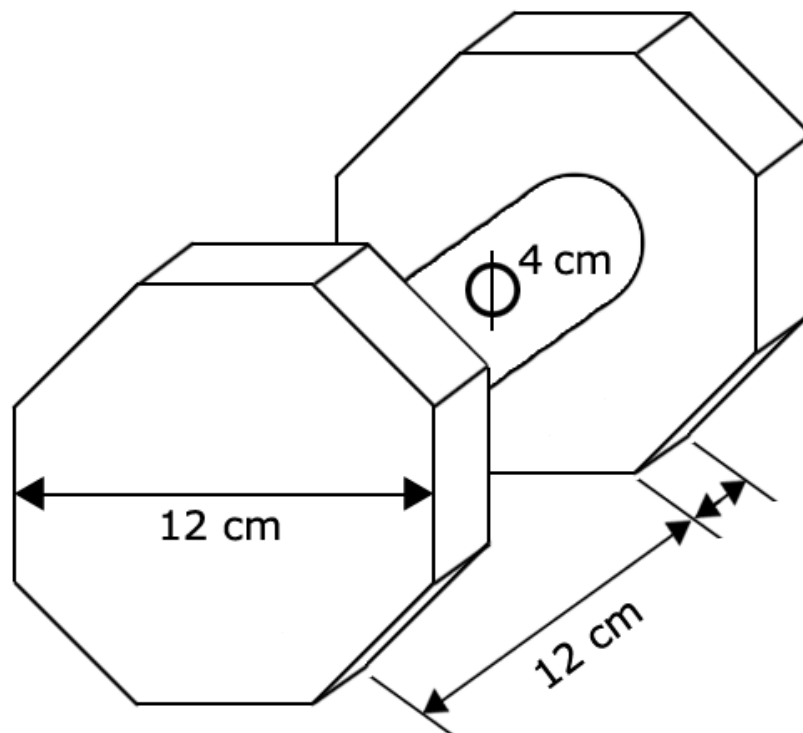

SchH II & III Scaling Wall

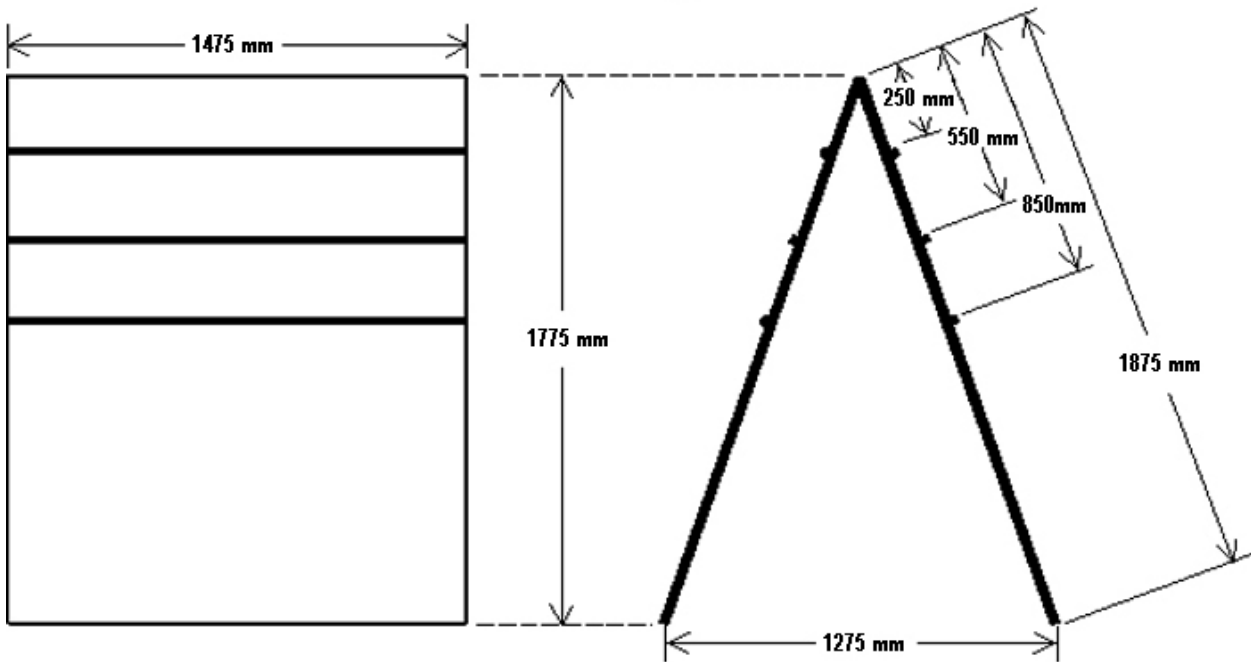

Size of cleats: 2.4 cm x 4.8 cm (approx. 1" x 2")

The Required Trial Heeling Pattern

Pattern may be worked with the turns in the opposite direction

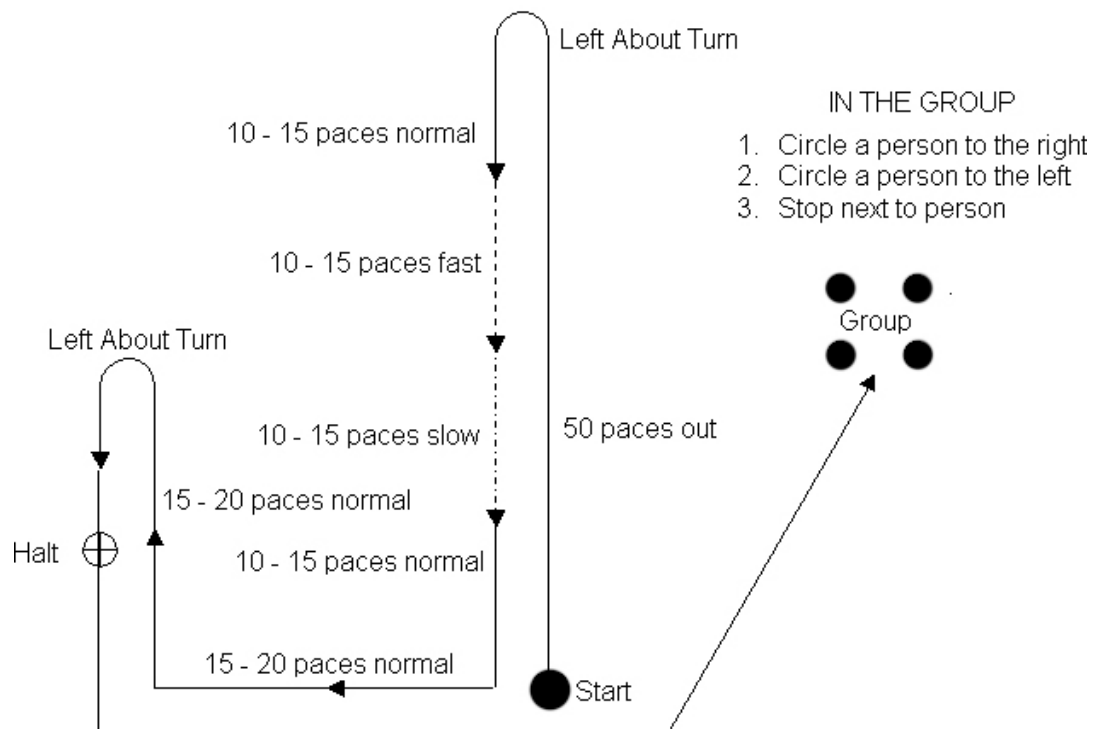

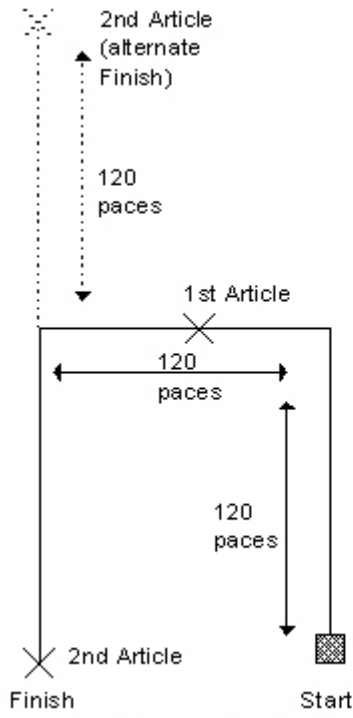

Schutzhund I Track
(you lay your own track at least 20 min. old)

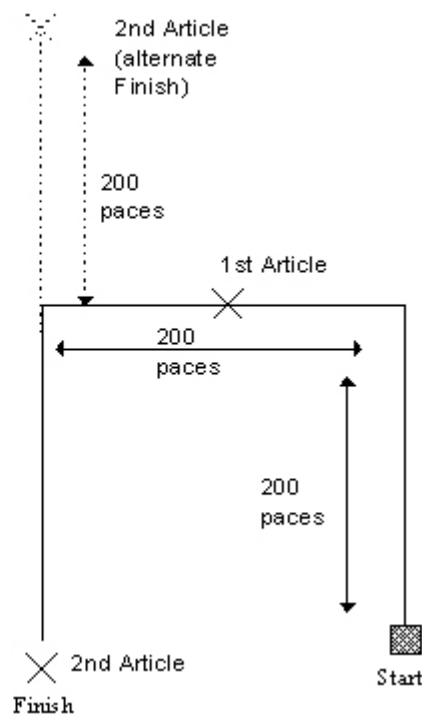

Schutzhund II Track
(laid by stranger at least 30 min. old)

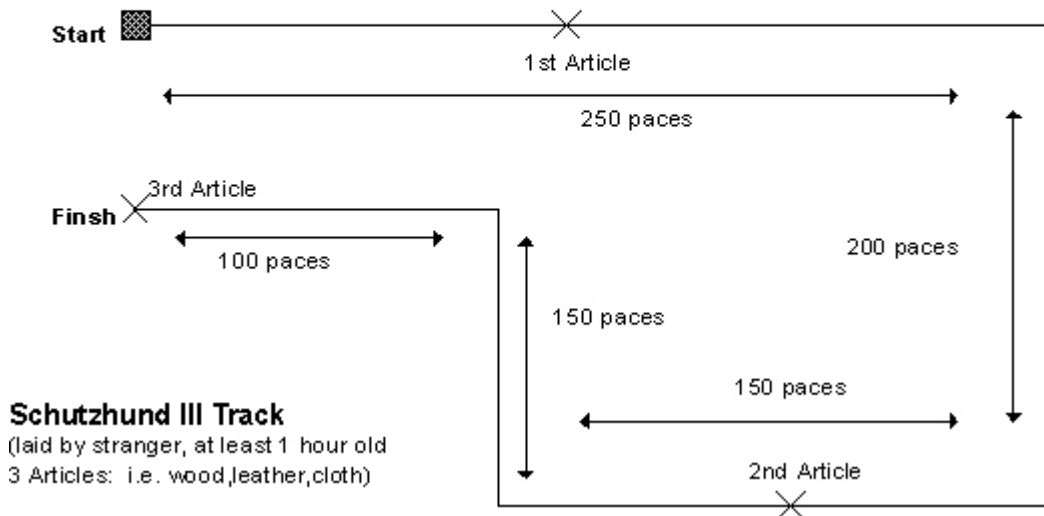

Schutzhund III Track
(laid by stranger, at least 1 hour old
3 Articles: i.e. wood, leather, cloth)